

Type 2030, 2031, 2031 K, 2032, 2033, 2037

Replacement of the seal set
Conversion of the control function

Wechsel von Dichtungssätzen
Umbau der Steuerfunktionen

Remplacement du jeu de joints
Transformation de la fonction de commande



Service Manual
Serviceanleitung
Service Manuel

We reserve the right to make technical changes without notice.
Technische Änderungen vorbehalten.
Sous réserve de modifications techniques.

© 2017 Bürkert Werke GmbH & Co. KG

Operating Instructions 1705/00804161_EUml_06 / Original DE

CONTENT

1	SERVICE MANUAL.....	5
1.1	Symbols.....	5
2	BASIC SAFETY INSTRUCTIONS	6
3	GENERAL INFORMATION.....	7
3.1	Contact addresses.....	7
3.2	Warranty	7
3.3	Information on the Internet.....	7
3.4	Auxiliary materials.....	7
4	EXPLODED DRAWING	8
5	REPLACEMENT OF THE DIAPHRAGM.....	10
5.1	Fastening types for diaphragms.....	10
5.2	Replacement of the diaphragm for control function A.....	11
5.3	Replacement of the diaphragm for control functions B and I.....	11
5.4	Replacing PTFE diaphragms with EPDM diaphragms.....	12
5.5	Tightening torques for body screws	13
6	REPLACING THE SEAL SET	14
6.1	Replacement of the seal set for control function A.....	15
6.2	Replacement of the seal set for control functions B and I	18
6.3	Tightening torques	20
6.3.1	Tightening torques for the nut	20
6.3.2	Tightening torques for the cover.....	21
7	CONVERSION OF THE CONTROL FUNCTION	22
7.1	Conversion of control function A to B.....	22
7.2	Conversion of control function A to I.....	25
8	INSTALLATION TOOLS.....	27
8.1	Installation wrench.....	27
8.2	Assembly sleeves	28

9	ORDERING THE PARTS	29
9.1	Seal set	29
9.2	Conversion kit	29
9.3	Diaphragm	30

1 SERVICE MANUAL

The service instructions describe the procedure for:

- Replacement of diaphragm and seal set of Type 2030, 2031, 2031 K, 2032, 2033 and 2037.
- Conversion of the control function of process valves of Type 2030, 2031, 2031 K, 2032, 2033 and 2037.

Keep these instructions in a location which is easily accessible to every user and make these instructions available to every new owner of the device.

Important safety information.

- ▶ Carefully read these instructions.
- ▶ Persons, who work on the device, must read and understand these instructions.



A detailed description of the device can be found in the operating instructions on the Internet at: www.burkert.com

1.1 Symbols



DANGER!

Warns of an immediate danger!

- ▶ Failure to observe the warning will result in fatal or serious injuries.



WARNING!

Warns of a potentially dangerous situation!

- ▶ Failure to observe the warning may result in serious injuries or death.



CAUTION!

Warns of a potential danger!

- ▶ Failure to observe the warning may result in a moderate or minor injury.

NOTE!

Warns of damage!

- ▶ Failure to observe the warning may result in damage to the device or other equipment.



Indicates important additional information, tips and recommendations.



Refers to information in these operating instructions or in other documentation.



Designates an instruction which you must follow to prevent a hazard.



Designates a procedure which you must carry out.

2 BASIC SAFETY INSTRUCTIONS

These safety instructions do not consider any contingencies or incidents which occur during assembly, operation and maintenance. The operator is responsible for observing the location-specific safety regulations, also with reference to the personnel.



Risk of injury from high pressure and discharge of medium.

- ▶ Before working on the system or device, switch off the pressure and vent or drain lines.

Risk of injury from electric shock.

- ▶ Before working on the device or system, switch off the power supply and secure to prevent reactivation.
- ▶ Observe applicable accident prevention and safety regulations for electrical equipment.

General hazardous situations.

To prevent injury, ensure the following:

- ▶ Operate the device only in perfect state and in consideration of the operating instructions.
- ▶ Do not transport, install or remove heavy devices without the aid of a second person and using suitable auxiliary equipment.
- ▶ Do not make any changes to the device and do not subject it to mechanical stress.
- ▶ Secure device or system to prevent unintentional activation.
- ▶ Only trained technicians may perform installation and maintenance work.
- ▶ Install the device according to the regulations applicable in the country.
- ▶ After an interruption in the power supply, ensure that the process is restarted in a controlled manner.
- ▶ Observe the general rules of technology.

3 GENERAL INFORMATION

3.1 Contact addresses

Germany

Bürkert Fluid Control Systems
Sales Center
Christian-Bürkert-Str. 13-17
D-74653 Ingelfingen
Tel. + 49 (0) 7940 - 10-91 111
Fax + 49 (0) 7940 - 10-91 448
Email: info@burkert.com

International

Contact addresses can be found on the final pages of the printed operating instructions.

And also on the Internet at:

www.burkert.com

3.2 Warranty

The warranty is only valid if the device is used as intended in accordance with the specified application conditions.

3.3 Information on the Internet

The operating instructions and data sheets for Bürkert products can be found on the Internet at:

www.burkert.com

3.4 Auxiliary materials

The following auxiliary materials are recommended in these instructions for carrying out the conversion and repairs:

Type of auxiliary material	Auxiliary materials	Manufacturer's specifications
Lubricant	Lagermeister SL	Fuchs Lubritech GmbH www.fuchs-lubritech.de
Lubricant	Amblygon TA 30/1	Klüber Lubrication München SE & Co. KG www.klueber.de
Liquid adhesive	Loctite 274	Henkel AG & Co. KGaA www.loctite.de

4 EXPLODED DRAWING

Control function A (CFA),
Closed in rest position by spring force

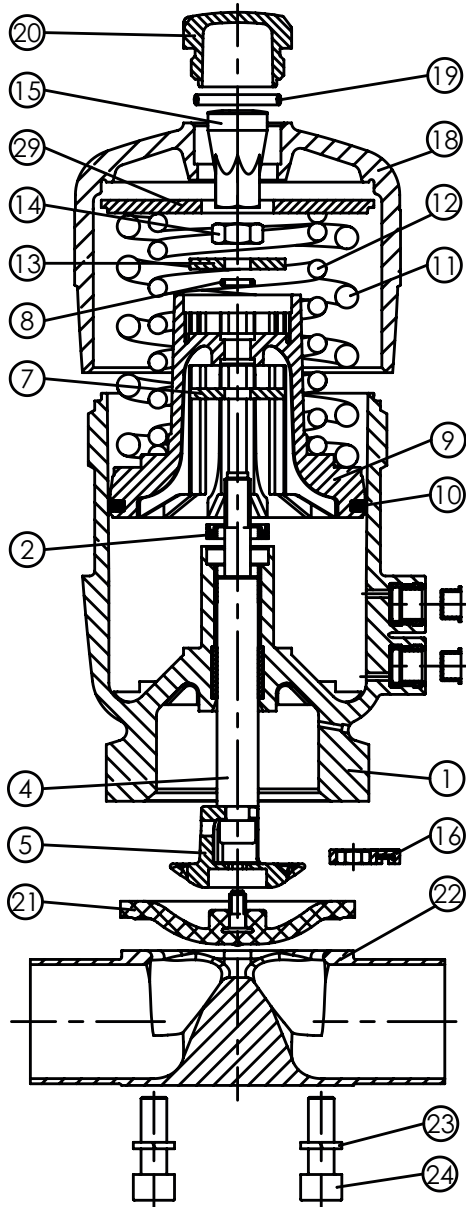

Control function B (CFB),
Open in rest position by spring force

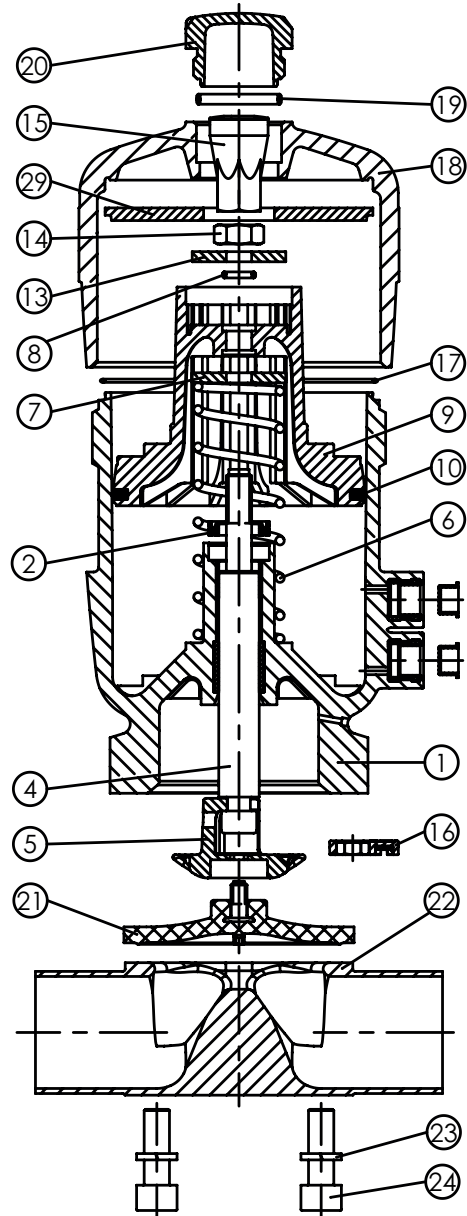

Control function I (CFI),
double-acting

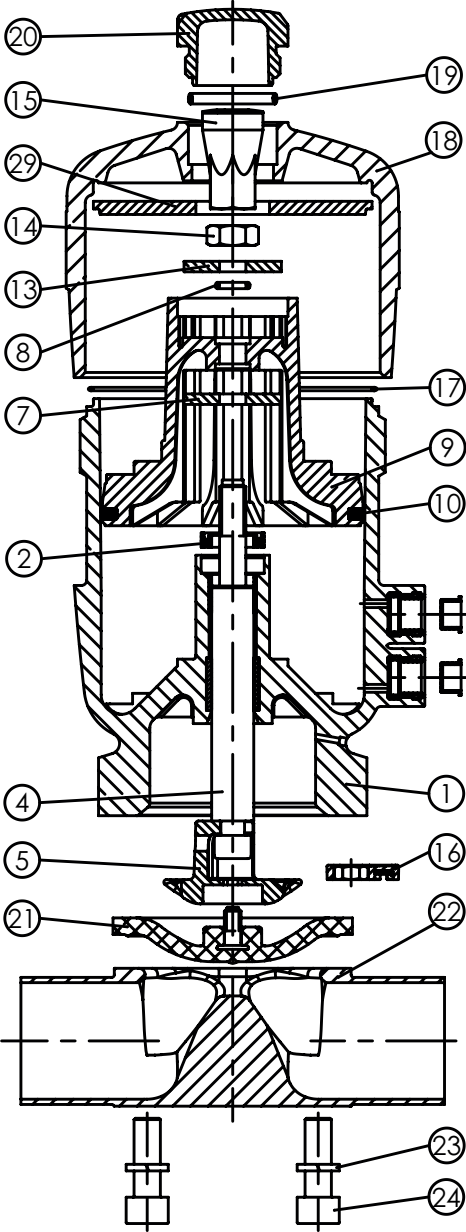

MAN 1000082679 ML Version: F Status: RL (released | freigegeben) printed: 22.09.2017

5 REPLACEMENT OF THE DIAPHRAGM

DANGER!

Risk of injury from high pressure and discharge of medium.

It is dangerous to remove the device under pressure due to the sudden pressure release or discharge of medium. During re-installation slacked body screws may cause a discharge of medium.

- ▶ Before removal, switch off the pressure and vent and drain the lines.
- ▶ During re-installation check tightening torque of the body screws.

This chapter describes the exact procedure for replacing the diaphragm.

Example

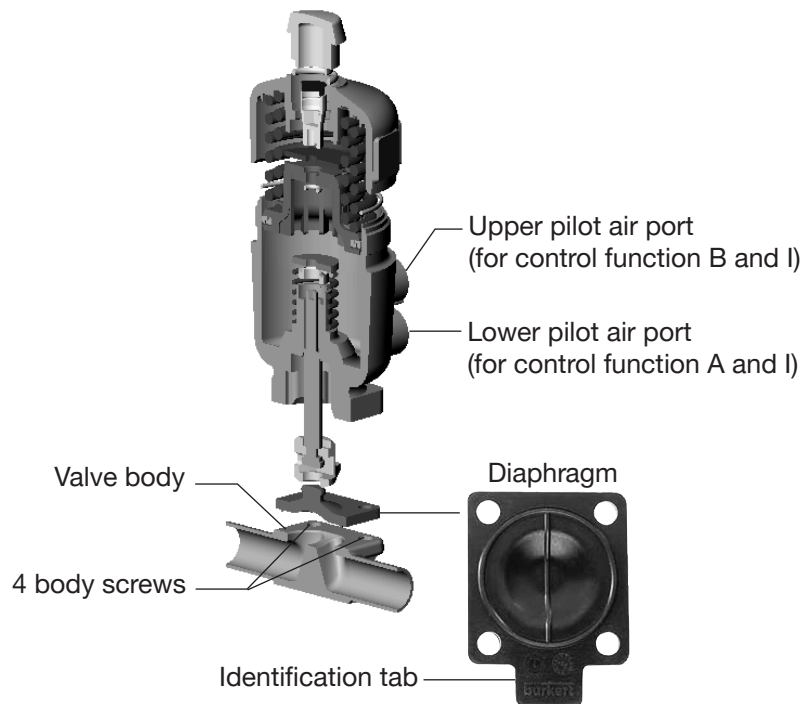

5.1 Fastening types for diaphragms

Diaphragm size	Fastening types for diaphragms	
	PTFE	EPDM / FKM / laminated PTFE
8	Diaphragm buttoned	Diaphragm buttoned
15	Diaphragm with bayonet catch	Diaphragm with bayonet catch (BC) ¹⁾
20		
25	Diaphragm with bayonet catch	Diaphragm screwed in
32		
40		
50		
65		

Table 1: Fastening types for diaphragms

1) Connection up to middle of 2015: Diaphragm buttoned

5.2 Replacement of the diaphragm for control function A

- Clamp the valve body (22) into a holding device (applies only to valves not yet installed).
- Pressurize lower pilot air port with compressed air (value as indicated on the type label).
- Loosen body screws (24) in diagonal pairs and remove actuator together with diaphragm from the valve body.
- Detach or unscrew damaged diaphragm (21).
If attachment is with a bayonet catch, remove the diaphragm by rotating it through 90°.
If the diaphragm size is 25 to 50, also observe chapter "5.4".
- Depending on the type of diaphragm, install the new diaphragm (21) in the actuator (1).
- Align diaphragm (21). Identification tab perpendicular to the direction of flow.
- Place actuator back on the valve body.
- Lightly tighten body screws (24) in diagonal pairs until the diaphragm is positioned between the valve body and actuator. Do not fully tighten body screws yet.
- Actuate the diaphragm valve twice to position the diaphragm correctly.
- Switch off control pressure (valve position closed).
- Tighten body screws (24) in diagonal pairs up to the permitted tightening torque. Observe the tightening torques in chapter "5.5".

5.3 Replacement of the diaphragm for control functions B and I

- Clamp the valve body (22) into a holding device (applies only to valves not yet installed).
- Loosen body screws (24) in diagonal pairs and remove actuator together with diaphragm from the valve body.
- Detach or unscrew damaged diaphragm (21).
If attachment is with a bayonet catch, remove the diaphragm by rotating it through 90°.
If the diaphragm size is 25 to 50, also observe chapter "5.4".
- Depending on the type of diaphragm, install the new diaphragm (21) in the actuator (1).
- Align diaphragm (21). Identification tab perpendicular to the direction of flow.
- Place actuator (1) back on the valve body.
- Lightly tighten body screws (24) in diagonal pairs until the diaphragm is positioned between the valve body and actuator. Do not fully tighten body screws yet.
- Pressurize upper pilot air port with compressed air (value as indicated on the type label).
For control functions B and I the pressure on the upper connection closes the valve.
- Actuate the diaphragm valve twice to position the diaphragm correctly.

→ Pressurize upper pilot air port with compressed air (valve position closed).

→ Tighten body screws (24) in diagonal pairs up to the permitted tightening torque. Observe the tightening torques in chapter "5.5".

→ Switch off control pressure.

5.4 Replacing PTFE diaphragms with EPDM diaphragms

Diaphragm size 8:

→ Detach PTFE diaphragm and press in new EPDM diaphragm.



The replacement described here for diaphragm sizes 15 to 50 is possible only for actuators which have been manufactured since the middle of 2015.

Diaphragm sizes 15 and 20:

→ Undo PTFE diaphragm bayonet and insert new EPDM diaphragm.

Diaphragm sizes 25 to 50:

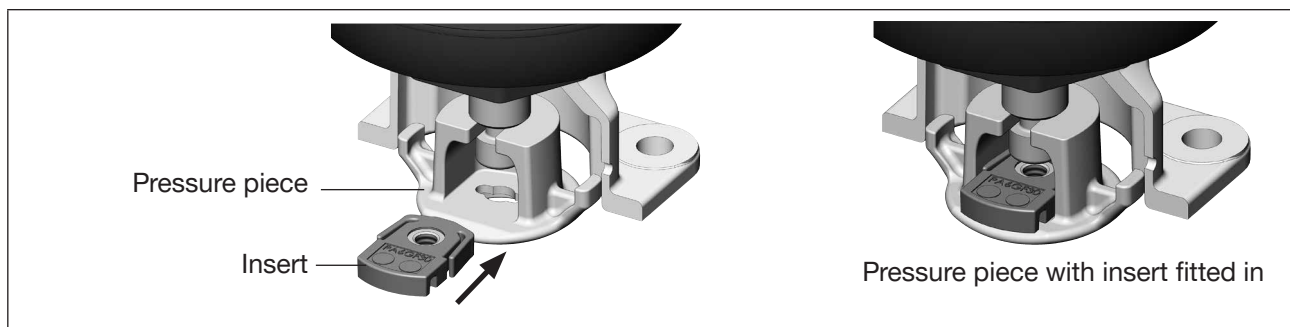

Figure 1: Fitting the insert into the pressure piece

→ Undo PTFE diaphragm bayonet.

→ Fit the insert into the pressure piece.

→ Insert and screw in EPDM diaphragm.

5.5 Tightening torques for body screws

Diaphragm size	Tightening torques [Nm]			
	VS, PP, PVC, PVDF, VG		VA and VP	
	EPDM / FKM	PTFE / advanced PTFE / laminated PTFE	EPDM / FKM	PTFE / advanced PTFE / laminated PTFE
8	2	2.5	2.5	2.5
15	3.5	4	3.5	4
20	4	4.5	4	4.5
25	5	6	7	8
32	6	8	8	10
40	8	10	12	15
50	12	15	15	20
65	20	30	-	-

Table 2: Tightening torques for the body screws

6 REPLACING THE SEAL SET

DANGER!

Risk of injury from high pressure in the system.

- ▶ Turn off the pressure and vent the lines before loosening lines or valves.

Risk of injury from improper maintenance work.

- ▶ Maintenance may be performed by authorized technicians only.
- ▶ Maintenance work may be performed by authorized technicians only and with the appropriate tools.
- ▶ Observe tightening torques of the body screws.

This chapter describes the exact procedure for replacing the seal set.

Difference between actuator size C (40 mm) and the other actuator sizes:

- Spindle (4) has a slot underneath instead of a hexagon socket,
- Pressure piece (5) split.

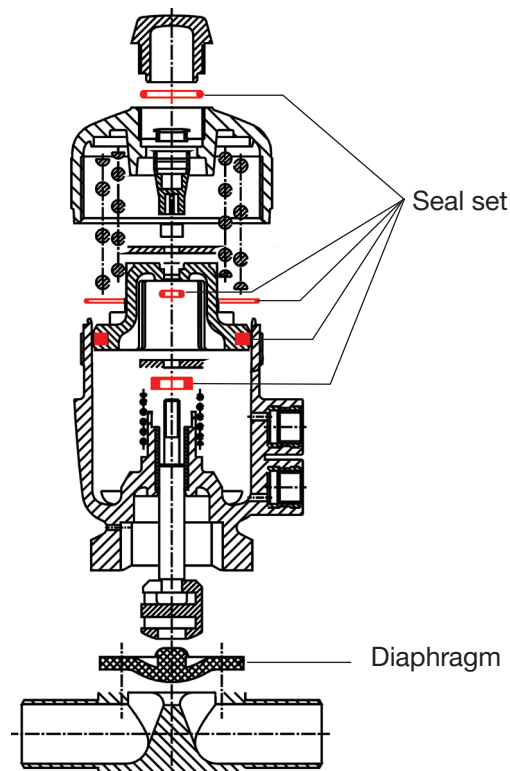

Required parts:

- 1 piston seal (10),
- 1 lip seal (2),
- 3 O-rings (8), (19), (17).

NOTE!

To replace all seals, the valve must be completely removed.

6.1 Replacement of the seal set for control function A

- Clamp the valve body (22) into a holding device (applies only to valves not yet installed).
- Pressurize lower pilot air port with compressed air (value as indicated on the type label).
- Loosen body screws (24) in diagonal pairs and remove actuator together with diaphragm from the valve body (22).
- Switch off pressure.
- Detach or unscrew diaphragm.
If attachment is with a bayonet catch, remove the diaphragm by rotating it through 90°.
- Clamp actuator on square of the actuator housing (1).
- Unscrew transparent cap (20) together with O-ring (19) from the cover (18).
- Unscrew cover (18) using installation wrench.



Information on the installation wrench can be found in the chapter Installation tools.

- For actuator sizes G and H only: remove disk (29).
- Take out pressure springs (11) and (12).
- Remove position indicator (15) using Allen key.
- Remove nut (14), countering the lower end of the spindle with Allen key or flat-blade screwdriver (4).
- Push out spindle (4) together with pressure piece (5) downwards.
- Carefully push out piston (9) together with upper support disk (13) from bottom to top.
- Remove lower shim washer (7) and O-ring (8) from the piston (9).
- Remove piston seal (10) from piston (9) and clean piston.
- For actuator size H: Carefully press locking washer over lip seal (2).
- Carefully remove lip seal (2) out of actuator housing (1).

NOTE!

Do not damage sealing surface on the actuator housing.



Remove grease and dirt from all internal parts.

- Lightly lubricate actuator housing ①:
PA actuator: with Lagermeister SL
PPS actuator: with Amblygon TA 30/1.
- Lightly lubricate seat for lip seal ② and spindle guide ④ in the actuator housing ① with Lagermeister SL or Amblygon TA 30/1.
- Insert lip seal ② into the actuator housing.
- **For actuator size H:** Press in locking washer.
- Lightly lubricate spindle ④ with Lagermeister SL or Amblygon TA 30/1.
- Using the assembly sleeve, push spindle ④ with pressure piece ⑤ from below all the way into the actuator housing.



Keep diaphragm and diaphragm contact point free of grease.

- Remove assembly sleeve from spindle.
- Clamp actuator on square of the actuator housing ①.
- Push lower shim washer ⑦ all the way onto the spindle ④.
- Lightly lubricate groove base on the piston ⑨ with Lagermeister SL or Amblygon TA 30/1.
- Insert new piston seal ⑩ and O-ring ⑧ into piston ⑨.
- Install piston ⑨ in the actuator housing.
- Push support disk ⑬ over spindle ④.
- Wet spindle thread with liquid adhesive Loctite 274.
- Tighten nut ⑭, countering the lower end of the spindle with Allen key or flat-blade screwdriver. Observe the tightening torques in chapter [“6.3.1”](#).
- Install position indicator ⑮ using Allen key. Tightening torque approx. 1.5 Nm.
- Insert pressure springs ⑪ and ⑫.
- **For actuator sizes G and H:** Put on washer ⑲.
- Insert new O-ring ⑱ into the cover ⑱.
- Lightly lubricate thread of the cover with Lagermeister SL or Amblygon TA 30/1.
- Screw cover ⑱ to the actuator housing using installation wrench. Observe the tightening torques in chapter [“6.3.2”](#).
- Screw in transparent cap ⑳. Tightening torque approx. 1.5 Nm.

- Install diaphragm depending on type of diaphragm.
- Align diaphragm (21). Identification tab perpendicular to the direction of flow.
- Clamp the valve body (22) into a holding device (applies only to valves not yet installed).
- Pressurize lower pilot air port with compressed air (value as indicated on the type label).
- Place actuator back on the valve body.
- Lightly tighten body screws (24) in diagonal pairs until the diaphragm is positioned between the valve body and actuator. Do not fully tighten body screws yet.
- Actuate the diaphragm valve twice to position the diaphragm correctly.
- Switch off control pressure (valve position closed).
- Tighten body screws (24) in diagonal pairs up to the permitted tightening torque. Observe the tightening torques in chapter [“5.5”](#).

6.2 Replacement of the seal set for control functions B and I

- Clamp the valve body (22) into a holding device (applies only to valves not yet installed).
- Loosen body screws (24) in diagonal pairs and remove actuator together with diaphragm from the valve body (22).
- Detach or unscrew diaphragm.
If attachment is with a bayonet catch, remove the diaphragm by rotating it through 90°.
- Clamp actuator on square of the actuator housing (1).
- Unscrew transparent cap (20) together with O-ring (19) from the cover (18).
- Unscrew cover (18) using installation wrench.



Information on the installation wrench can be found in the chapter Installation tools.

- For actuator sizes G and H only: remove disk (29).
- Remove position indicator (15) using Allen key.



WARNING!

Risk of injury when opening the actuator for control function B.

The actuator contains a tensioned spring. If the housing is opened, there is a risk of injuries from the spring jumping out.

- ▶ Carefully open the actuator housing and hold it in such a way that any parts which jump out cannot injure anyone or damage anything.

- Remove nut (14), countering the lower end of the spindle (4) with Allen key or flat-blade screwdriver.
- Carefully remove piston (9) together with upper shim washer (13).
- Remove lower shim washer (7) and O-ring (8).
- For control function B: Take out pressure spring (6).
- Push out spindle (4) together with pressure piece (5) downwards.
- For actuator size H: Carefully press locking washer over lip seal (2).
- Carefully remove lip seal (2) from the actuator housing (1).

NOTE!

Do not damage sealing surface on the actuator housing.

 Remove grease and dirt from all internal parts.

- Lightly lubricate actuator housing (1):
PA actuator: with Lagermeister SL
PPS actuator: with Amblygon TA 30/1.
- Lightly lubricate seat for lip seal (2) and spindle guide (4) in the actuator housing with Lagermeister SL or Amblygon TA 30/1.
- Insert lip seal (2) into the actuator housing.
- **For actuator size H:** Press in locking washer.
- Lightly lubricate spindle (4) with Lagermeister SL or Amblygon TA 30/1.
- Using the assembly sleeve, push spindle (4) with pressure piece (5) from below all the way into the actuator housing.

 Keep diaphragm and diaphragm contact point free of grease.

- Remove assembly sleeve from spindle.
- Clamp actuator on square of the actuator housing (1).
- **For control function B:** Insert pressure spring (6).
- **For control function I:** Do not insert pressure spring.
- Push lower shim washer (7) all the way onto the spindle (4).
- Remove piston seal (10) from piston (9) and clean piston.
- Lightly lubricate groove base on the piston (9) with Lagermeister SL or Amblygon TA 30/1.
- Insert new piston seal (10) and O-ring (8) into piston (9).
- **For control function B:** Install piston with pretensioned spring in the actuator housing (1); to do this, manually press in pressure spring (6) together with piston (9) until the spindle thread protrudes through the bore and hold in this position.
- Push support disk (13) all the way onto the spindle (4).
- Wet spindle thread with liquid adhesive Loctite 274.
- Tighten nut (14), countering the lower end of the spindle with Allen key or flat-blade screwdriver. Observe the tightening torques in chapter "6.3.1".
- **For actuator sizes G and H:** Put on washer (29).
- Insert new O-ring (17).

- Insert new O-ring (19) into the cover (18).
- Lightly lubricate thread of the cover with Lagermeister SL or Amblygon TA 30/1.
- Screw down cover (18) using installation wrench. Observe the tightening torques in chapter “6.3.2”.



Information on the installation wrench can be found in the chapter Installation tools.

- Install position indicator (15) using Allen key. Tightening torque approx. 1.5 Nm.
- Screw in transparent cap (20). Tightening torque approx. 1.5 Nm.
- Install diaphragm depending on type of diaphragm.
- Align diaphragm (21). Identification tab perpendicular to the direction of flow.
- Clamp the valve body (22) into a holding device (applies only to valves not yet installed).
- Place actuator back on the valve body (22).
- Lightly tighten body screws (24) in diagonal pairs until the diaphragm is positioned between the valve body and actuator. Do not fully tighten body screws yet.
- Pressurize upper pilot air port with compressed air (value as indicated on the type label).
- Actuate the diaphragm valve twice to position the diaphragm correctly.
- Pressurize upper pilot air port with compressed air (valve position closed).
- Tighten body screws (24) in diagonal pairs up to the permitted tightening torque. Observe the tightening torques in chapter “5.5”.
- Switch off control pressure.

6.3 Tightening torques

6.3.1 Tightening torques for the nut

Designation of the parts	Actuator size	Tightening torque [Nm] (guide value)
Nut (Pos. 14)	C	3.5
	D, E	5.0
	F	10.0
	G, H	20.0

Table 3: Tightening torques for the nut

6.3.2 Tightening torques for the cover

Designation of the parts	Actuator size	Tightening torque [Nm] (guide value)
Cover (Pos. 18)	C	25.0
	D	35.0
	E	40.0
	F	60.0
	G	80.0
	H	110.0

Table 4: *Tightening torques for the cover*

7 CONVERSION OF THE CONTROL FUNCTION



DANGER!

Risk of injury from high pressure in the system.

- ▶ Turn off the pressure and vent the lines before loosening lines or valves.

Risk of injury from improper maintenance work.

- ▶ Maintenance may be performed by authorized technicians only.
- ▶ Maintenance work may be performed by authorized technicians only and with the appropriate tools.
- ▶ Observe tightening torques of the body screws.

This chapter describes the exact procedure for converting control function A to B and control function A to I for the following actuator sizes:

- C (40 mm), D (50 mm), E (63 mm), F (80 mm), G (100 mm) and H (125 mm).

Difference between actuator size C (40 mm) and the other actuator sizes:

- Spindle ④ has a slot underneath instead of a hexagon socket,
- Pressure piece ⑤ split.

7.1 Conversion of control function A to B

Required parts:

- 1 pressure spring ⑥
- 1 O-ring ⑰

→ Clamp the valve body ⑳ into a holding device (applies only to valves not yet installed).

→ Pressurize lower pilot air port with compressed air (value as indicated on the type label).

→ Loosen body screws ㉔ in diagonal pairs and remove actuator together with diaphragm from the valve body ㉒.

→ Switch off pressure.

→ Detach or unscrew diaphragm.

If attachment is with a bayonet catch, remove the diaphragm by rotating it through 90°.

→ Clamp actuator on the square of the actuator housing ①.

→ Unscrew cover ⑱ using installation wrench.

→ **For actuator sizes G and H only:** remove disk ㉑.

→ Remove pressure springs ⑪ and ⑫.

- Remove position indicator (15) using Allen key.
- Loosen nut (14), countering the lower end of the spindle with Allen key or flat-blade screwdriver (4).
- Carefully remove piston (9) together with upper support disk (13).

NOTE!

Do not damage sealing surface on the actuator housing.

- Remove lower shim washer (7) and O-ring (8).
- Lightly lubricate actuator housing (1):
PA actuator: with Lagermeister SL
PPS actuator: with Amblygon TA 30/1.
- Insert pressure spring (6).
- Push lower shim washer (7) and O-ring (8) all the way onto the spindle.
- Install piston (9) with pretensioned pressure spring (6) into the actuator housing; to do this, manually press in pressure spring together with piston until the spindle thread protrudes through the bore. Hold piston in this position (if required, use the removed pressure spring to press in the piston).
- Push support disk (13) over spindle (4).
- Wet spindle thread with liquid adhesive Loctite 274.
- Fit nut (14) and relieve the pressure spring against the nut.
- Tighten nut (14), countering the lower end of the spindle with Allen key or flat-blade screwdriver. Observe the tightening torques in chapter "6.3.1".
- Install position indicator (15) using Allen key. Tightening torque approx. 1.5 Nm.
- **For actuator sizes G and H:** Put on washer (29).
- Insert O-ring (17) into the groove of the actuator housing.
- Lightly lubricate thread of the cover with Lagermeister SL or Amblygon TA 30/1.
- Screw down cover (18) using installation wrench. Observe the tightening torques in chapter "6.3.2".



Information on the installation wrench can be found in the chapter Installation tools.

- Install diaphragm depending on type of diaphragm.
- Align diaphragm (21). Identification tab perpendicular to the direction of flow.
- Clamp the valve body into a holding device (applies only to valves not yet installed).
- Place actuator back on the valve body (22).

- Lightly tighten body screws (24) in diagonal pairs until the diaphragm is positioned between the valve body and actuator. Do not fully tighten body screws yet.
- Pressurize upper pilot air port with compressed air (value as indicated on the type label).
- Actuate the diaphragm valve twice to position the diaphragm correctly.
- Pressurize upper pilot air port with compressed air (valve position closed).
- Tighten body screws (24) in diagonal pairs up to the permitted tightening torque. Observe the tightening torques in chapter [“5.5”](#).
- Switch off control pressure.

7.2 Conversion of control function A to I

Required parts:

- 1 O-ring (17)

- Clamp the valve body (22) into a holding device (applies only to valves not yet installed).
- Pressurize lower pilot air port with compressed air (value as indicated on the type label).
- Loosen body screws (24) in diagonal pairs and remove actuator together with diaphragm from the valve body (22).
- Switch off pressure.
- Detach or unscrew diaphragm.
If attachment is with a bayonet catch, remove the diaphragm by rotating it through 90°.
- Clamp actuator on the square of the actuator housing (1).
- Unscrew cover (18) using installation wrench.
- **For actuator sizes G and H only:** remove disk (29).
- Remove pressure springs (11) and (12).
- Remove position indicator (15) using Allen key.
- Loosen nut (14), countering the lower end of the spindle with Allen key or flat-blade screwdriver (4).
- Carefully remove piston (9) together with upper support disk (13).

NOTE!

Do not damage sealing surface on the actuator housing.

- Remove lower shim washer (7) and O-ring (8).
- Lightly lubricate actuator housing (1):
PA actuator: with Lagermeister SL
PPS actuator: with Amblygon TA 30/1.
- Push lower shim washer (7) and O-ring (8) all the way onto the spindle.
- Insert piston (9) into the actuator housing (1) and push over spindle thread.
- Push support disk (13) over spindle (4).
- Wet spindle thread with liquid adhesive Loctite 274.
- Fit and tighten nut (14), countering the lower end of the spindle with Allen key or flat-blade screwdriver.
Observe the tightening torques in chapter "6.3.1".

- Install position indicator (15) using Allen key. Tightening torque approx. 1.5 Nm.
- **For actuator sizes G and H:** Put on washer (29).
- Insert O-ring (17) into the groove of the actuator housing.
- Lightly lubricate thread of the cover with Lagermeister SL or Amblygon TA 30/1.
- Screw down cover (18) using installation wrench. Observe the tightening torques in chapter "6.3.2".
- Install diaphragm depending on type of diaphragm.
- Align diaphragm (21). Identification tab perpendicular to the direction of flow.
- Clamp the valve body into a holding device (applies only to valves not yet installed).
- Place actuator back on the valve body (22).
- Lightly tighten body screws (24) in diagonal pairs until the diaphragm is positioned between the valve body and actuator housing. Do not fully tighten body screws yet.
- Pressurize upper pilot air port with compressed air (value as indicated on the type label).
- Actuate the diaphragm valve twice to position the diaphragm correctly.
- Pressurize upper pilot air port with compressed air (valve position closed).
- Tighten body screws (24) in diagonal pairs up to the permitted tightening torque. Observe the tightening torques in chapter "5.5".
- Switch off control pressure.

8 INSTALLATION TOOLS

8.1 Installation wrench

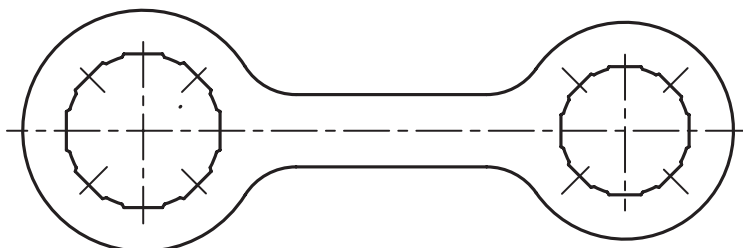

Installation wrench actuator size C, D		
Actuator	ø (mm)	Order number
C	40	639 175
D	50	639 175

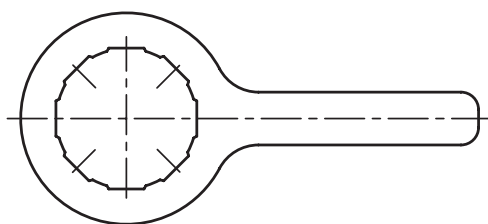

Installation wrench actuator size E		
Actuator	ø (mm)	Order number
E	63	639 170

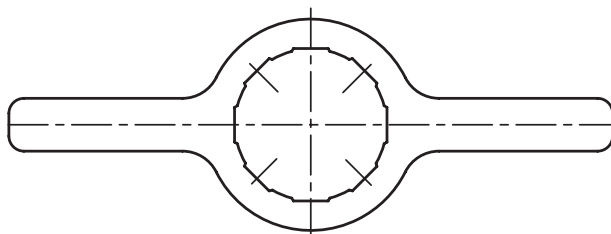

Installation wrench actuator size F, G, H		
Actuator	ø (mm)	Order number
F	80	639 171
G	100	639 172
H	125	639 173

8.2 Assembly sleeves

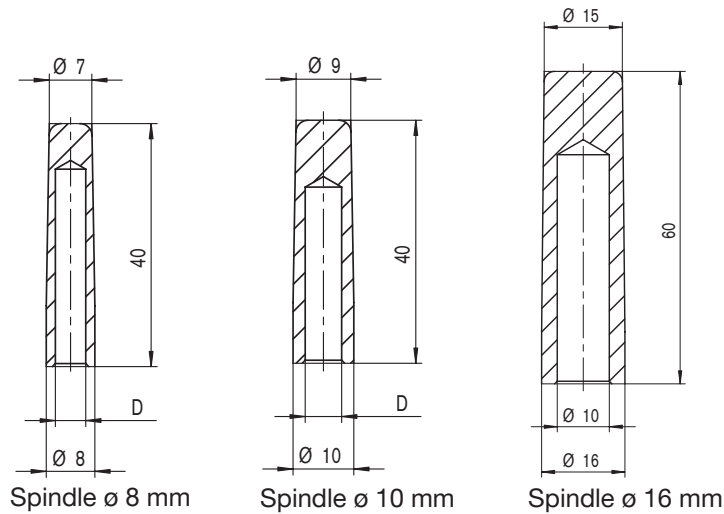

Assembly sleeve for spindle \varnothing 8 mm

Actuator size	Diaphragm size	Dimension D (mm)	Order number
C (40 mm)	8	\varnothing 5	639 165
D (50 mm)	15	\varnothing 6	639 166

Assembly sleeve for spindle \varnothing 10 mm

Actuator size	Diaphragm size	Dimension D (mm)	Order number
E (63 mm)	15, 20, 25	\varnothing 6	639 167
F (80 mm)	15, 20, 25	\varnothing 8	639 168

Assembly sleeve for spindle \varnothing 16 mm

Actuator size	Diaphragm size	Dimension D (mm)	Order number
G (100 mm)	32, 40, 50	-	639 169
H (125 mm)	40, 50, 65	-	639 169

9 ORDERING THE PARTS

CAUTION!

Risk of injury and/or damage due to the use of incorrect parts.

Incorrect accessories and unsuitable spare parts may cause injuries and damage the device and the surrounding area.

► Use original accessories and original spare parts from Bürkert only.

9.1 Seal set

Actuator size	Diaphragm size	Order number	
		PPS actuator	PA actuator
C (40 mm)	8	011 465	-
D (50 mm)	15	011 477	011 426
E (63 mm)	15, 20, 25	011 488	011 440
F (80 mm)	15, 20, 25	011 492	011 448
G (100 mm)	32, 40, 50	012 127	012 125
H (125 mm)	40, 50, 65	011 494	011 464

Table 5: Order numbers for the seal set

9.2 Conversion kit

Actuator size	Order number	
	Conversion kit CFA after CFB	Conversion kit CFA after CFI
C (40 mm)	011 678	001 948
D (50 mm)	011 681	011 744
E (63 mm)	011 685	011 766
F (80 mm)	011 689	011 767
G (100 mm)	011 710	011 795
H (125 mm)	011 715	011 813

Table 6: Order numbers for the conversion kit

9.3 Diaphragm

Dia- phragm size	Order numbers for diaphragms											
	EPDM (AB*)		EPDM (AD*)		FKM (FF*)		PTFE (EA*)		Advanced PTFE (EU*)		Gylon laminated (ER*)	
8	677 663	E02**	688 421	E03**	677 684	F01**	677 674	L04**	679 540	L05**	693 175	L06**
15	677 664	E02**	688 422	E03**	677 685	F01**	677 675	E02- PTFE**	679 541	E02- PTFE+ hole**	693 176	L06**
15 BC**	693 162	E02**	693 163	E03**	693 164	F01**	-	-	-	-	-	-
20	677 665	E02**	688 423	E03**	677 686	F01**	677 676	E02- PTFE**	679 542	E02- PTFE+ hole**	693 177	L06**
20 BC**	693 165	E02**	693 166	E03**	693 167	F01**	-	-	-	-	-	-
25	677 667	E01**	688 424	E03**	677 687	F01**	677 677	E02- PTFE**	679 543	E02- PTFE+ hole**	693 178	L06**
32	677 668	E01**	688 425	E03**	677 688	F01**	677 678	E02- PTFE**	679 544	E02- PTFE+ hole**	693 179	L06**
40	677 669	E01**	688 426	E03**	677 689	F01**	677 679	E02- PTFE**	679 545	E02- PTFE+ hole**	693 180	L06**
50	677 670	E01**	688 427	E03**	677 690	F01**	677 680	E02- PTFE**	679 546	E02- PTFE+ hole**	693 181	L06**
65	677 671	E01**	688 428	E03**	677 691	F01**	677 681	E02- PTFE**	679 743	E02- PTFE+ hole**	-	-

Table 7: Order numbers for the diaphragms

* SAP code

** Designation on the diaphragm



Data sheet, operating instructions and other information on the type can be found on the Internet at:
www.burkert.com.

If you have any queries, please contact your Bürkert sales office.

