

# STAINLESS STEEL-PRESSURE FILTER

Series EH 31 6000 PSI

Sheet No.  
1435 F

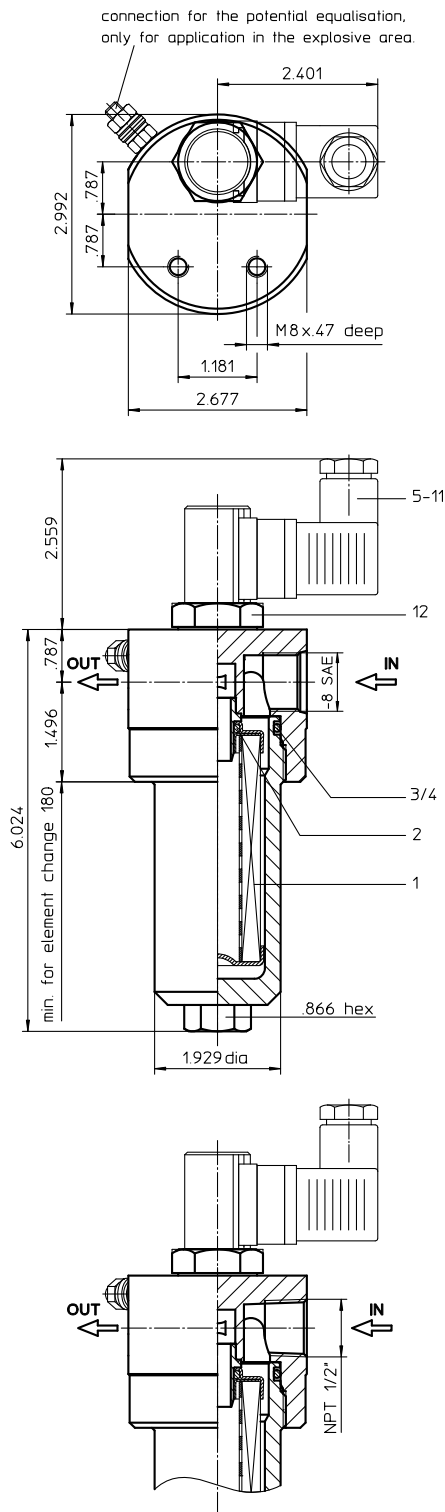

## 1. Type index:

### 1.1. Complete filter: (ordering example)

**EH. 31. 10VG. HR. E. P. VA. UG. 3. VA. -. AE**

1	2	3	4	5	6	7	8	9	10	11	12
---	---	---	---	---	---	---	---	---	----	----	----

- 1 **series:**  
EH = stainless steel-pressure filter
- 2 **nominal size:** 31
- 3 **filter-material and filter-fineness:**  
80 G = 80  $\mu\text{m}$ , 40 G = 40  $\mu\text{m}$ , 25 G = 25  $\mu\text{m}$   
stainless steel wire mesh  
25 VG = 20  $\mu\text{m}_{(c)}$ , 16 VG = 15  $\mu\text{m}_{(c)}$ , 10 VG = 10  $\mu\text{m}_{(c)}$ ,  
6 VG = 7  $\mu\text{m}_{(c)}$ , 3 VG = 5  $\mu\text{m}_{(c)}$  Interpor fleece (glass fiber)
- 4 **resistance of pressure difference for filter element:**  
30 =  $\Delta p$  435 PSI  
HR =  $\Delta p$  2320 PSI (rupture strength  $\Delta p$  3625 PSI)
- 5 **filter element design:**  
E = single-end open
- 6 **sealing material:**  
P = Nitrile (NBR)  
V = Viton (FPM)
- 7 **filter element specification:** (see catalog)  
- = standard  
VA = stainless steel  
IS06 = see sheet-no. 31601
- 8 **connection:**  
UG = thread connection  
NPT = thread connection
- 9 **connection size:**  
3 = -8 SAE or 1/2" NPT
- 10 **filter housing specification:**  
VA = stainless steel
- 11 **internal valve:**  
- = without  
S1 = with by-pass valve  $\Delta p$  51 PSI  
S2 = with by-pass valve  $\Delta p$  102 PSI
- 12 **clogging indicator or clogging sensor:**  
- = without  
AOR = visual, see sheet-no. 1606  
AOC = visual, see sheet-no. 1606  
AE = visual-electrical, see sheet-no. 1615  
VS1 = electronical, see sheet-no. 1617  
VS2 = electronical, see sheet-no. 1618

### 1.2. Filter element: (ordering example)

**01E. 30. 10VG. HR. E. P. -**

1	2	3	4	5	6	7
---	---	---	---	---	---	---

- 1 **series:**  
01E. = filter element according to company standard
- 2 **nominal size:** 30
- 3 - 7 see type index-complete filter

weight: approx. 7 lbs.

Changes of measures and design are subject to alteration!

EDV 03/15



Friedensstrasse 41, 68804 Altlussheim, Germany

phone +49 (0)6205 2094-0  
fax +49 (0)6205 2094-40

e-mail info-internormen@eaton.com  
url [www.eaton.com/filtration](http://www.eaton.com/filtration)

## 2. Spare parts:

item	qty.	designation	dimension	article-no.	
1	1	filter element	01E. 30		
2	1	O-ring	11 x 3	312603 (NBR)	312727 (FPM)
3	1	O-ring	42 x 3,5	329381 (NBR)	338204 (FPM)
4	1	support ring	48 x 2,6 x 1	305391	
5	1	clogging indicator, visual	AOR or AOC	see sheet-no. 1606	
6	1	clogging indicator, visual-electrical	AE	see sheet-no. 1615	
7	1	clogging sensor, electrical	VS1	see sheet-no. 1617	
8	1	clogging sensor, electrical	VS2	see sheet-no. 1618	
9	1	O-ring	15 x 1,5	315357 (NBR)	315427 (FPM)
10	1	O-ring	22 x 2	304708 (NBR)	304721 (FPM)
11	1	O-ring	14 x 2	304342 (NBR)	304722 (FPM)
12	1	screw plug	20913-4	314442	

item 12 execution only without clogging indicator or clogging sensor

## 3. Description:

The pressure filters of the series EH 31 are suitable for a working pressure up to 6000 PSI.

The pressure peaks are absorbed by a sufficient margin of safety. The EH-filter is in-line mounted.

The filter element consists of star-shaped, pleated filter material which is supported on the inside by a perforated core tube and is bonded to the end caps with a high-quality adhesive. The flow direction is from outside to the inside. Filter elements are available down to 4  $\mu\text{m}_{(c)}$ .

Internormen Product Line filter elements are known as elements with a high intrinsic stability and an excellent filtration capability, a high dirt-retaining capacity and a long service life.

Internormen Product Line filter are suitable for all petroleum based fluids, HW-emulsions, most synthetic hydraulic fluids and lubrication oils.

Internormen Product Line filter elements are available up to a pressure difference resistance of  $\Delta p$  2320 PSI and a rupture strength of  $\Delta p$  3625 PSI.

The internal valves are integrated into the centering pivot for the filter element.

After reaching the opening pressure the by-pass valve causes that an unfiltered partial flow passes the filter

## 4. Technical data:

temperature range:	+14°F to + 176°F (for a short time + 212°F)
operating medium:	mineral oil, other media on request
max. operating pressure:	6000 PSI
test pressure:	8700 PSI
connection system:	thread connection
housing material:	DIN 17440 - 1.4571 (316 Ti according to AISI)
sealing material:	Nitrile (NBR) or Viton (FPM), other materials on request
installation position:	vertical
volume tank:	.03 Gal

Classified under the Pressure Equipment Directive 97/23/EC for mineral oil (fluid group 2), Article 3, Para. 3.

Classified under ATEX Directive 94/9/EC according to specific application (see questionnaire sheet-no. 34279-4).

## 5. Symbols:

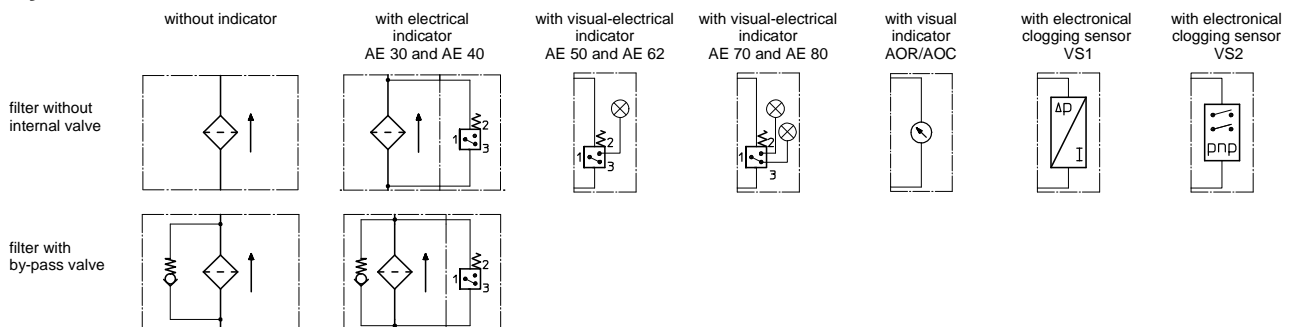

**6. Pressure drop flow curves:** Precise flow rates see 'Interactive Product Specifier', respectively  $\Delta p$ -curves; depending on filter fineness and viscosity.

## 7. Test methods:

Filter elements are tested according to the following ISO standards:

ISO 2941	Verification of collapse/burst resistance
ISO 2942	Verification of fabrication integrity
ISO 2943	Verification of material compatibility with fluids
ISO 3723	Method for end load test
ISO 3724	Verification of flow fatigue characteristics
ISO 3968	Evaluation of pressure drop versus flow characteristics
ISO 16889	Multi-pass method for evaluating filtration performance