

Type 8644 AirLINE

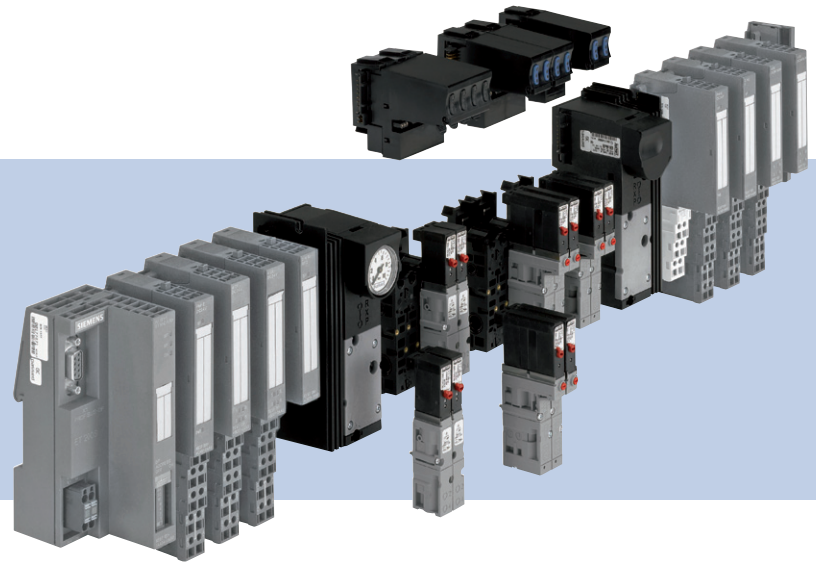

Quickstart

English Deutsch Français

We reserve the right to make technical changes without notice.
Technische Änderungen vorbehalten.
Sous réserve de modifications techniques.

© Bürkert Werke GmbH & Co. KG, 20FFÁ 2017

Operating Instructions 1705/EF_ÖEP_008EJ FI / Original DE

1. QUICKSTART	4	6. ASSEMBLY	8
1.1. Definition of the term "Device"	4	6.1. Safety instructions	8
1.2. Symbols.....	4	6.2. Assembly.....	9
2. INTENDED USE	5	6.3. Removing the valve block from the standard rail	12
2.1. Restrictions.....	5	7. INSTALLATION	13
3. GENERAL SAFETY INFORMATION	5	7.1. Fluid Installation	13
4. GENERAL INFORMATION	6	7.2. Fluid deinstallation	15
4.1. Contact address.....	6	7.3. Electrical Installation.....	15
4.2. Warranty	6	8. START-UP	16
4.3. Informations in the Internet.....	6	8.1. Safety instructions	16
5. TECHNICAL DATA	7	8.2. Fluid start-up	16
5.1. Conformity	7	8.3. Electrical start-up.....	16
5.2. Standards.....	7	9. MAINTENANCE	16
5.3. General Technical Data	7	10. TRANSPORT, STORAGE, DISPOSAL	16

1. QUICKSTART

The operating instructions describe the entire life cycle of the device. Keep these instructions in a location which is easily accessible to every user and make these instructions available to every new owner of the device.

Important Safety Information!

Read Quickstart carefully and thoroughly. Study in particular the chapters entitled "[General safety information](#)" and "[Intended use](#)".

- Quickstart must be read and understood.

The Quickstart explains, for example, how to install and start-up the device.

A detailed description of the device can be found in the operating instructions for Type 8644.



The operating instructions can be found on the enclosed CD and on the Internet at:

www.burkert.com

1.1. Definition of the term "Device"

In these instructions, the term "device" always refers to the system AirLINE type 8644.

1.2. Symbols

The following symbols are used in these instructions.



DANGER!

Warns of an immediate danger!

- Failure to observe the warning may result in a fatal or serious injury.



WARNING!

Warns of a potentially dangerous situation!

- Failure to observe the warning may result in serious injuries or death.



CAUTION!

Warns of a possible danger!

- Failure to observe this warning may result in a moderately severe or minor injury.

NOTE!

Warns of damage to property!



Important tips and recommendations.



Refers to information in these operating instructions or in other documentation.

→ designates a procedure which you must carry out.

2. INTENDED USE

Non-intended use of the AirLINE Type 8644 may be a hazard to people, nearby equipment and the environment.

- The device is designed for use in an environment where there is a risk of explosion (only Type 8644 Siemens and Wago). Pneumatically operated devices may be used for control.
- Do not supply the medium connectors of the system with aggressive or flammable media.
- Do not use the device outdoors unprotected.
- Do not physically stress the housing (e.g. by placing objects on it or standing on it).
- Use according to the authorized data, service and operating conditions specified in the contract documents and operating instructions. These are described in the chapter entitled "*Technical data*".
- The device may be used only in conjunction with third-party devices and components recommended and authorized by Bürkert.
- Correct transportation, storage, and installation, as well as careful use and maintenance are essential for reliable and faultless operation.
- Use the device only as intended.

2.1. Restrictions

If exporting the system/device, observe any existing restrictions.

3. GENERAL SAFETY INFORMATION

This safety information does not cover:

- Haphazard situations that can arise during installation, operation and maintenance of the use.
- Locally applicable safety regulations which the operator and installation personnel are obligated to follow.



General Hazardous Situations.

To prevent injuries:

- Ensure that the system cannot be activated unintentionally.
- Note that pipes and valves must not become detached in systems which are under pressure.
- Before reaching into the system, always switch off the power supply.
- Design the pressure supply with the largest possible volume to prevent a pressure drop when the system is switched on.
- Installation and maintenance work may be carried out only by authorized technicians with the appropriate tools.
- After an interruption in the power supply or pneumatic supply, ensure that the process is restarted in a defined or controlled manner.
- The device may be operated only when in perfect condition and in consideration of the operating instructions.
- The general rules of technology must be observed for application planning and operation of the device.

Risk of burns/risk of fire if used continuously through hot device surface!

- Keep the device away from highly flammable substances and media and do not touch with bare hands.



The Type 8644 AirLINE was developed with due consideration given to accepted safety rules and is state-of-the-art. Nevertheless, dangerous situations may occur.

NOTE!

Electrostatic sensitive components/modules!

The device contains electronic components, which react sensitively to electrostatic discharge (ESD). Contact with electrostatically charged persons or objects is hazardous to these components. In the worst case scenario, they will be destroyed immediately or will fail after start-up.

- Observe the requirements in accordance with EN 61340-5-1 and 5-2 to minimize/avoid the possibility of damage caused by a sudden electrostatic discharge!
- Also, ensure that you do not touch electronic components when the power supply voltage is present!

4. GENERAL INFORMATION

4.1. Contact address

Germany

Bürkert Fluid Control Systems
Sales Center
Christian-Bürkert-Str. 13-17
D-74653 Ingelfingen
Tel. + 49 (0) 7940 - 10 91 111
Fax + 49 (0) 7940 - 10 91 448
E-mail: info@de.buerkert.com

International

Contact addresses are found on the final pages of this operating manual.

And also on the Internet under: www.burkert.com

4.2. Warranty

The warranty is only valid if the AirLINE Type 8644 is used as intended in accordance with the specified application conditions.

4.3. Informations in the Internet

The operating manual and the data sheets on Type 8644 can be found on the Internet under: www.burkert.com

5. TECHNICAL DATA

5.1. Conformity

The system AirLINE type 8644 conforms with the EC Directives according to the EC Declaration of Conformity.

5.2. Standards

The applied standards, which verify conformity with the EC Directives, can be found on the EC-Type Examination Certificate and / or the EC Declaration of Conformity.

5.3. General Technical Data

Technical Data	Pilot valve type 0460, 6524, 6525	Pilot valve type 0461, 6526, 6527
Pressure range	Vac. up to 10 bar	Vac. up to 10 bar
Operating voltage	24 V DC	24 V DC
Voltage tolerance	+20 % / -15 % (when using Type 0460: ± 10 %)	+20 % / -15 % (when using Type 0461: ± 10 %)
Ambient temperature	0 ... +55 °C (when using Type 0460 and 0461: 0 ... +50 °C)	

5.3.1. Rating plate

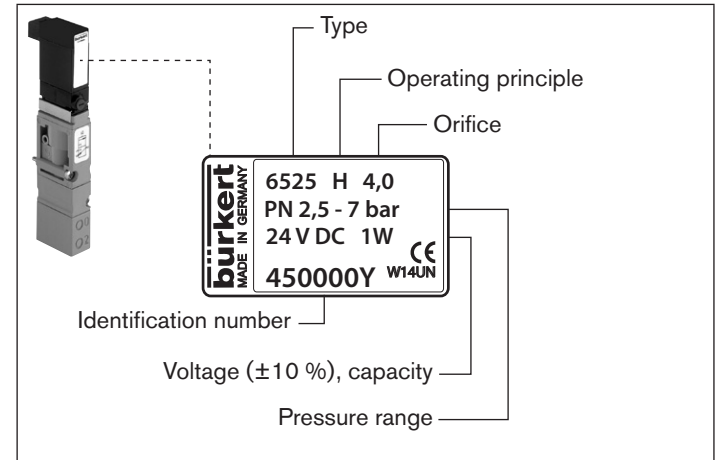

Fig. 1: Location and description of the rating plate

5.3.2. Fluid connection

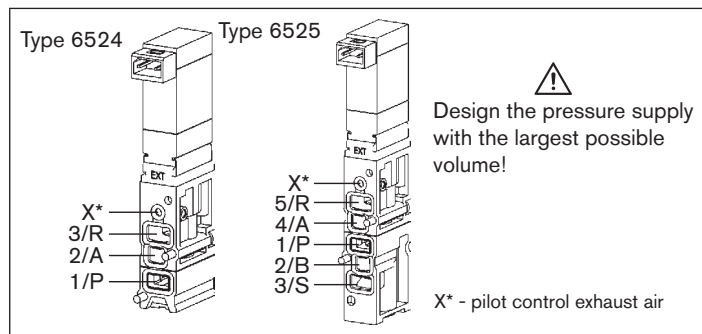

Fig. 2: Fluid connection. Types 6524 and 6525

5.3.3. Fluid and electrical connection

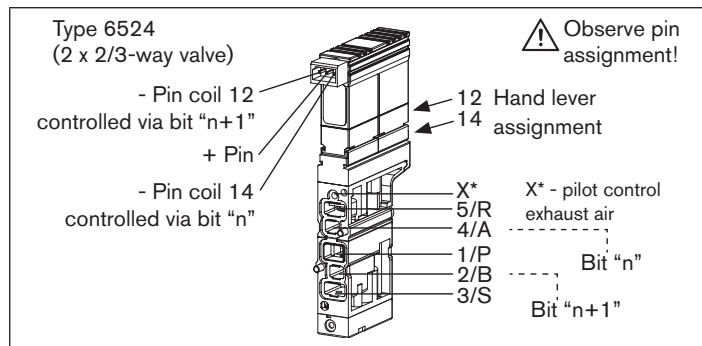

Fig. 3: Fluid and electrical connection. Type 6524

6. ASSEMBLY

6.1. Safety instructions



DANGER!

Risk of injury from high pressure in the equipment!

- Before loosening lines or valves, turn off the pressure and vent the lines.

Risk of injury due to electrical shock!

- Before reaching into the device or the equipment, switch off the power supply and secure to prevent reactivation!
- Observe applicable accident prevention and safety regulations for electrical equipment!



WARNING!

Risk of injury from improper assembly!

- Installation may only be carried out by authorized technicians with the appropriate tools!

Risk of injury from unintentional activation of the system and uncontrolled restart!

- Secure system from unintentional activation.
- Following assembly, ensure a controlled restart.

CAUTION!

Escape of medium and malfunction!

If the seals are not seated correctly, leaks and malfunctions may occur due to pressure losses.

- Ensure that the seals are seated correctly in the area of the electronics and pneumatics.

Short-circuit, malfunction!

The electrical connection requires exact contacting.

- Do not bend contacts.
- If connections are damaged or bent, replace the affected components.
- Do not switch on the system unless the components are in perfect condition.

NOTE!

Operate the system with direct current only!

To prevent damage to the system, use only direct current for the system power supply.

Prevent a pressure drop!

To prevent a pressure drop, design the system pressure supply with the largest possible volume.

6.2. Assembly

DANGER!

Danger of explosion!

If systems in the explosion-protected area are installed in a control cabinet, the following requirements must be met:

- The control cabinet must be authorized for use in the explosion-protected area.
- The control cabinet must be large enough to allow the resulting lost heat to be dissipated in a suitable manner to the outside.
- The internal temperature of the control cabinet must not exceed the max. permitted ambient temperature for the device.

Risk of electric shock!

- Before reaching into the device or the equipment, switch off the power supply and secure to prevent reactivation!

6.2.1. Installation on standard rail

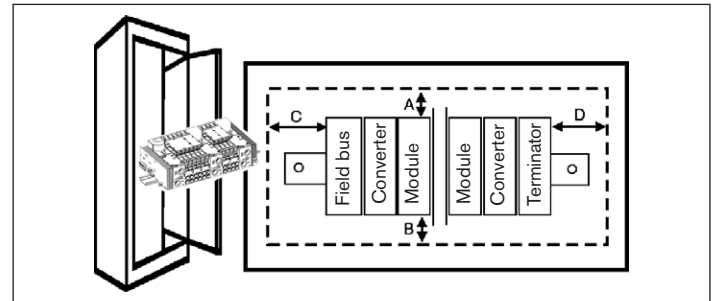

Fig. 4: Installation of a valve block into a control cabinet

- Fasten the standard rail firmly in the control cabinet.
- Establish a short, wide PE connection between the standard rail and the control cabinet.

! The valve terminal must be freely accessible from above. Ensure good heat dissipation!

Recommended distance when installing in a control cabinet:

A	30 mm	C	30 mm
B	30 mm	D	60 mm

6.2.2. Installation of AirLINE Quick

To install AirLINE Quick, a notch must be first of all provided on the base or the wall of the control cabinet, e.g. through lasing or punching.

For the dimensions of the relevant flange image, refer to chapter [“Tab. 1: Dimensions of the flange images for AirLINE Quick”](#).

The distances to the left, right, front and top depend on the selected valve terminal configuration.

Recommended distance in the control cabinet to the valve terminal:

left	right	front	top
30 mm	60 mm	30 mm	50 mm

HINWEIS!

The opening on the control cabinet must be burr-free to prevent damage to the seal of the AirLINE Quick adapter.

- Without damaging the seal of the AirLINE Quick adapter, insert it into the groove of the flange opening.

- Position the valve terminal in the control cabinet on the prepared opening.
- From outside attach the stability plate to prevent distortion and secure with screws M 5 x 10 from the enclosed fastening set.

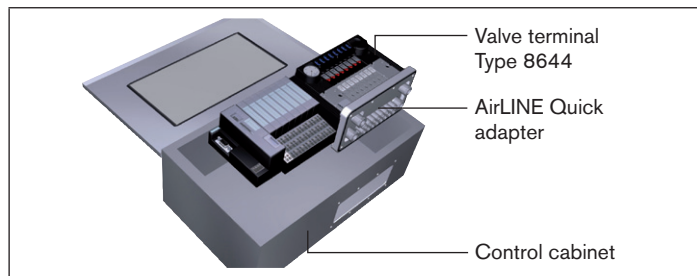

Fig. 5: Placing the valve terminal in the control cabinet

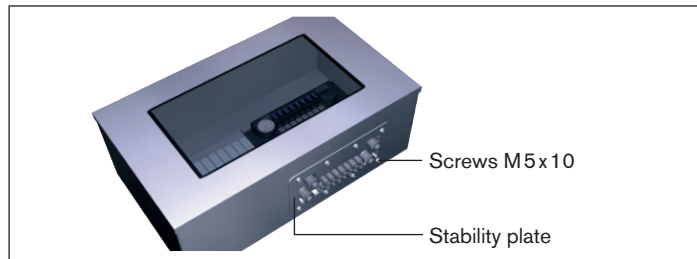

Fig. 6: Attaching the stability plate

6.2.3. Dimensions of the flange images for AirLINE Quick

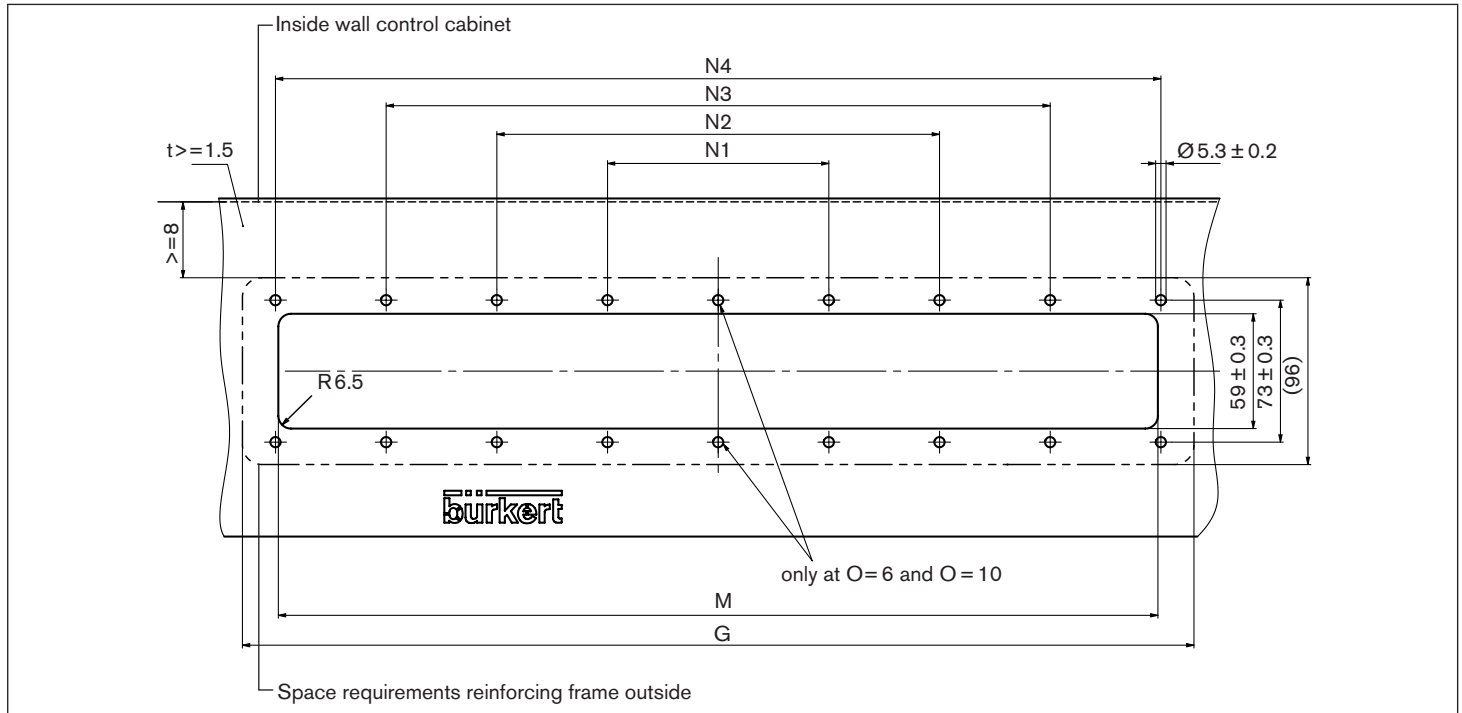

Fig. 7: Dimensions of the flange images for AirLINE Quick – for dimensions see ["Tab. 1", page 12](#)

Feature	Version				
	8-fold	12-fold	16-fold	16-fold	20-fold
M	155 ±0.4	199 ±0.4	243 ±0.4	276 ±0.4	287 ±0.4
N1	54 ±0.3	68 ±0.3	123 ±0.4	140 ±0.4	145 ±0.4
N2	158 ±0.4	202 ±0.4	246 ±0.4	279 ±0.4	290 ±0.4
N3	–	–	–	–	–
N4	–	–	–	–	–
O (Number of bores)	8	8	10	10	10
G	192	236	280	313	324

Feature	20-fold	24-fold	24-fold	32-fold
	3)	–	1)	3)
M	320 ±0.4	331 ±0.4	364 ±0.4	452 ±0.4
N1	65 ±0.3	66 ±0.3	73 ±0.3	65 ±0.3
N2	193 ±0.4	200 ±0.4	219 ±0.4	195 ±0.4
N3	323 ±0.4	334 ±0.4	367 ±0.4	325 ±0.4
N4	–	–	–	455 ±0.4
O (Number of bores)	12	12	12	16
G	357	368	401	489

Tab. 1: Dimensions of the flange images for AirLINE Quick

- 1) with intermediate feed
- 2) on request
- 3) with intermediate feed on request

6.3. Removing the valve block from the standard rail



DANGER!

Risk of electric shock!

- Before reaching into the device or the equipment, switch off the power supply and secure to prevent reactivation.

The valve block is bolted securely onto the standard rail. Additional electrical modules / terminals can be aligned in rows on the sides of the valve block.

Procedure:

- Detach the adjacent modules/terminals (if fitted).
- Release the attachment of the valve block on the standard rail. To do this, turn the fastening screws all the way counter-clockwise.

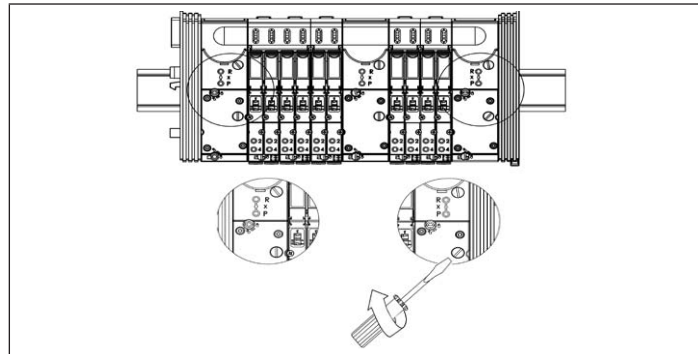

Fig. 8: Releasing the attachment of the valve block on the standard rail

- Lift the valve block vertically off the standard rail.

! There must be adequate space between valve block and predecessor module > 6 mm.

→ Detach the modules/terminals from the standard rail according to the manufacturer's description.

NOTE!

The interface of the left connection module contains elements which may break off if force is used.

- Never place the valve block on its side and observe the permitted installation position.

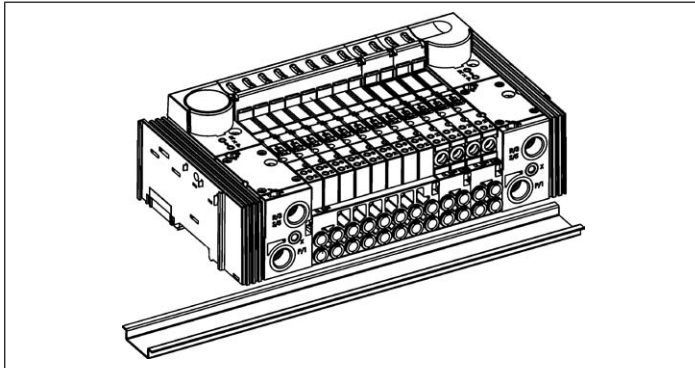

Fig. 9: Detaching the modules/terminals from the standard rail

NOTE!

- When screwing the valve block back onto the standard rail, observe a max. torque of 2 Nm!

7. INSTALLATION

7.1. Fluid Installation

! **DANGER!**

Risk of injury from high pressure in the equipment!

- Before loosening lines or valves, turn off the pressure and vent the lines.
- Design the connections with the largest possible volume.
- Close the open connections not required with lock screws.
- The connections for the pilot control exhaust air (x) must not be sealed.
- Check correct assignment of the connections 1 and 3 or 5. They may by no means be interchanged.

7.1.1. Pneumatic connections - feed

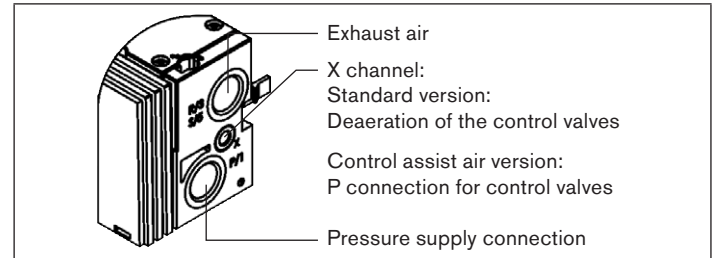

Fig. 10: Pneumatic Connections

Procedure:

→ Depending on the version, plug the connections in the corresponding working connections or screw them in.

NOTE!

For the plug-in connections the hose pipes must meet the following requirements:

- Minimum hardness of 40 Shore D (in accordance with DIN 53505 or ISO 868);
- Outer diameter in accordance with DIN 73378 (max. permitted deviation ± 0.1 mm of the nominal dimension);
- Burr-free, cut off at right angles and undamaged on the outer diameter;

The hose pipes must be pressed all the way into the plug-in connections.

7.1.2. Removing the plug-in connections

→ To detach the pipes, press in the thrust ring and pull out the hose pipe.

7.1.3. Pneumatic connections – AirLINE standard

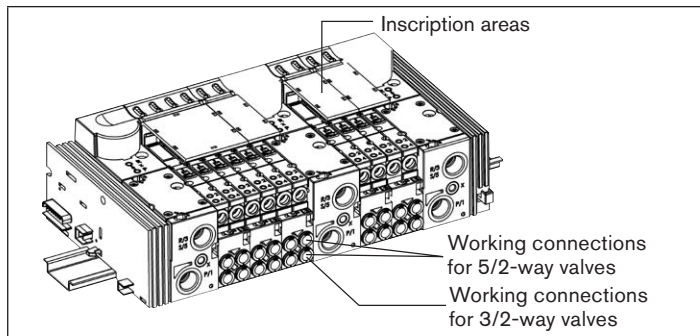

Fig. 11: Pneumatic connections - valve discs

Procedure:

→ Depending on the version, plug the connections in the corresponding working connections or screw them in.

→ Connection nipples can be used for threaded versions.

Inscription of the connections:

→ Label the inscription areas with the data of the valve connections.

7.1.4. Pneumatic connections – AirLINE Quick

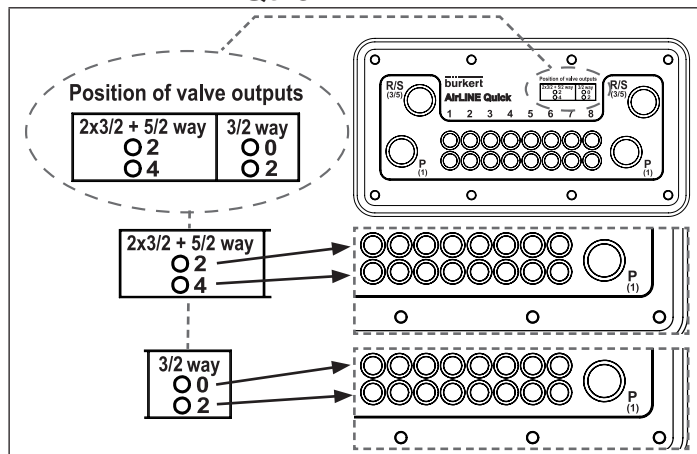

Fig. 12: Pneumatic connections – AirLINE Quick

Procedure:

→ Depending on the version, plug the connections in the corresponding working connections.

7.1.5. Fluid connection AirLINE Quick

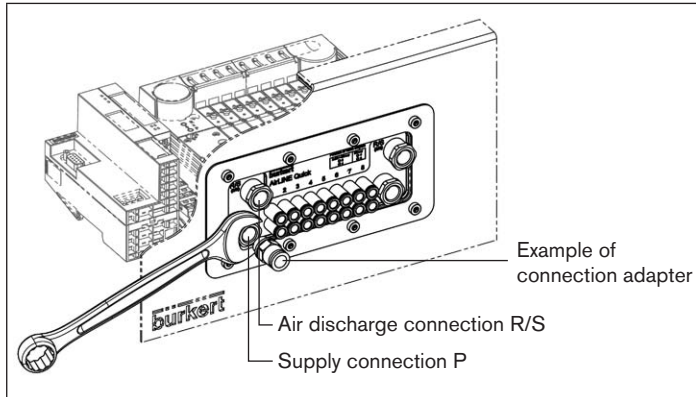

Fig. 13: Fluid connection AirLINE Quick

Procedure:

→ Screw connection adapter G1/4" or NPT 1/4" to connections P and R/S.

NOTE!

Risk of leakage if screw connection is too tight!

- When fitting the fluid connection adapters to the connections P, R/S, observe the max. torque of 12 Nm. In doing so, counter with a suitable tool to prevent the connections from turning!

7.2. Fluid deinstallation

NOTE!

Irreversible damage to the seal in the thread of the screw connection!

- When loosening the connection adapters, use a suitable tool to prevent the corresponding supply or air discharge connection from turning.

7.3. Electrical Installation



DANGER!

Risk of injury due to electrical shock!

- Before reaching into the device or the equipment, switch off the power supply and secure to prevent reactivation!

The electrical installation of the AirLINE system corresponds to the installation of the decentralized peripheral device (depending on the relevant cooperation partner Siemens, Wago, Phoenix or Rockwell).

Refer to the manuals provided by the cooperation partners for a more detailed description.

8. START-UP

8.1. Safety instructions



WARNING!

Risk of injury from improper operation!

Improper operation may result in injuries as well as damage to the device and the area around it.

- Before start-up, ensure that the operating personnel are familiar with and completely understand the contents of the operating instructions.
- Observe the safety instructions and intended use.
- Only adequately trained personnel may start up the equipment/ the device.

8.2. Fluid start-up

NOTE!

- Switch on the supply pressure.
- Only then switch on the power supply!

Procedures before fluid start-up:

- Check connections, voltage and operating pressure.
- Ensure that max. operating data are not exceeded.
- Check correct assignment of the connections 1 and 3 or 5. They may by no means be interchanged.
- Release manual actuation during electrical operation.

8.3. Electrical start-up

The start-up of the AirLINE system corresponds to the installation of the decentralized peripheral device (depending on the relevant cooperation partner Siemens, Wago, Phoenix or Rockwell).

Refer to the manuals provided by the cooperation partners for a more detailed description.

9. MAINTENANCE

See [“7.2. Fluid deinstallation”, page 15.](#)

10. TRANSPORT, STORAGE, DISPOSAL

NOTE!

Transport damages!

Inadequately protected equipment may be damaged during transport.

- During transportation protect the device against wet and dirt in shock-resistant packaging.
- Avoid exceeding or dropping below the permitted storage temperature.

Incorrect storage may damage the device!

- Store the device in a dry and dust-free location!
- Storage temperature: -20 ... +60 °C.

Damage to the environment caused by device components contaminated with media!

- Ensure the device and packaging are disposed of in an environmentally sound manner.
- Observe applicable regulations relating to refuse disposal and the environment.
- Observe the national waste disposal regulations.

www.burkert.com