

Type S030 HT

High Temperature INLINE fitting

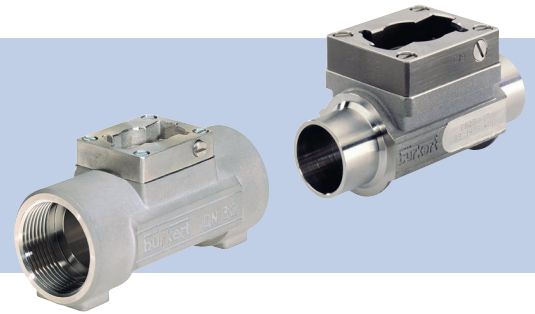

Operating Instructions

Bedienungsanleitung
Manuel d'utilisation

We reserve the right to make technical changes without notice.
Technische Änderungen vorbehalten.
Sous réserve de modifications techniques.

www.burkert.com

© 2010-2016 Bürkert SAS
Operating Instructions 1603/03_EU-ML_00563877_ORIGINAL_FR

MAN 1000290428 EN Version: D Status: RL (released | freigegeben) printed: 22.09.2017

1. ABOUT THIS MANUAL.....	3
2. INTENDED USE.....	5
3. BASIC SAFETY INFORMATION	6
4. GENERAL INFORMATION	9
5. DESCRIPTION.....	10
6. TECHNICAL DATA	11
7. INSTALLATION.....	22
8. MAINTENANCE.....	30
9. SPARE PARTS AND ACCESSORIES	32
10. PACKAGING, TRANSPORT, STORAGE.....	35

1. ABOUT THIS MANUAL

This manual describes the entire life cycle of the fitting. Please keep this manual in a safe place, accessible to all users and any new owners.

This manual contains important safety information.

Failure to comply with these instructions can lead to hazardous situations.

- This manual must be read and understood.

Symbols used



DANGER

Warns against an imminent danger.

- Failure to observe this warning can result in death or in serious injury.



WARNING

Warns against a potentially dangerous situation.

- Failure to observe this warning can result in serious injury or even death.

**ATTENTION****Warns against a possible risk.**

- Failure to observe this warning can result in substantial or minor injuries.

NOTE**Warns against material damage.**

- Failure to observe this warning may result in damage to the fitting or system.



Indicates additional information, advice or important recommendations.



Refers to information contained in this manual or in other documents.

→ Indicates a procedure to be carried out.

3. BASIC SAFETY INFORMATION

This safety information does not take into account:

- any contingencies or occurrences that may arise during installation, use and maintenance of the devices.
- the local safety regulations for which the operating company is responsible including the staff in charge of installation and maintenance.



Danger due to high pressure in the installation.

Danger due to high temperatures of the fluid.

Danger due to the nature of the fluid.

**Various dangerous situations**

- Prevent any power supply switch-on.
- Ensure that installation and maintenance work are carried out by qualified, authorised personnel in possession of the appropriate tools.
- Guarantee a set or controlled restarting of the process, after a power supply interruption.

2. INTENDED USE**Use of fittings S030 HT that does not comply with the instructions could present risks to people, nearby installations and the environment.**

- The S030 HT fitting is intended to measure the flow rate of clean fluids in the piping thanks to its paddle wheel. The fitting S030 HT can be combined with an electronic module SE30 HT to build a flowmeter 8030 HT.
- Use this fitting in compliance with the specifications and conditions of commissioning and use given in the contractual documents, in this user manual and in the user manual for the device which is inserted into it.
- Safe and trouble-free operation of the fitting depends on its proper transport, storage and installation, as well as careful operation and maintenance.
- Only use this fitting as intended.

**Various dangerous situations**

- Observe the general technical rules when installing and using the fitting.
- Use the fitting only if in perfect working order and in compliance with the instructions provided in the instruction manual.
- Do not use the fitting in explosive atmospheres.
- Do not use this fitting to measure gas flow rates.
- Do not use fluid that is incompatible with the materials from which the fitting is made.
- Do not use this fitting in an environment incompatible with the materials from which it is made.
- Do not subject the fitting to mechanical loads (by placing objects on top of it or by using it as a step, for example).
- Do not make any external modifications to the fitting. Do not paint any part of the fitting.

NOTE

The fitting may be damaged by the fluid in contact with.

- Systematically check the chemical compatibility of the component materials of the fitting and the fluids likely to come into contact with it (for example: alcohols, strong or concentrated acids, aldehydes, alkaline compounds, esters, aliphatic compounds, ketones, halogenated aromatics or hydrocarbons, oxidants and chlorinated agents).

4. GENERAL INFORMATION

To contact the manufacturer of the fitting use following address:

Bürkert SAS

Rue du Giessen

BP 21

F-67220 TRIEMBACH-AU-VAL

The addresses of our international branches can be found on the Internet at: www.burkert.com

Warranty conditions

The condition governing the legal warranty is the conforming use of the S030 HT in observance of the operating conditions specified in this manual.

Information on the Internet

You can find the user manuals and technical data sheets regarding the type S030 at: www.burkert.com

5. DESCRIPTION

Area of application

The S030 HT fitting is intended to measure the flow rate of clean fluids in DN6 to DN50 pipes thanks to its paddle-wheel. Its combination with an SE30 HT electronic module builds a flowmeter 8030 HT.

The electronic device can be removed without opening the piping or stopping the process.

Measuring principle

The fluid flowing in the piping makes the paddle-wheel turn. The paddle-wheel rotational frequency f is proportional to the flow rate.

6. TECHNICAL DATA

Conditions of use

Ambient temperature (operating)	-15 to +80 °C, if the fitting is combined with an SE30 HT electronic module
Pressure class	<ul style="list-style-type: none">▪ PN40 if $-15\text{ °C} < T\text{ fluid} < 90\text{ °C}$▪ PN25 if $90\text{ °C} < T\text{ fluid} \leq 125\text{ °C}$
Fluid temperature	-15 to +125 °C

Conformity to the pressure directive

The S030 HT fitting complies with article 3 of §3 of the pressure equipment directive 97/23/CE.

According to this directive, the product can only be used in the following cases (depending on max. pressure, pipe diameter and fluid):

Type of fluid	Conditions
Fluid group 1 § 1.3.a	only DN ≤ 25
Fluid group 2 § 1.3.a	DN ≤ 32 or DN > 32 and PNxDN ≤ 1000
Fluid group 1 § 1.3.b	PNxDN ≤ 2000
Fluid group 2 § 1.3.b	DN ≤ 200

Fluid data

Max. Fluid viscosity	300 cSt
Type of fluid	Clean, neutral or slightly aggressive
Rate of solid particles in the fluid	max. 1 %
Max. particle size	0,5 mm
Measurement range of the flow rate in the pipe	0,5 to 10 m/s
Measurement deviation	<ul style="list-style-type: none"> ▪ Standard K-factor ▪ Teach-In
Linearity	± 0,5 % of the full scale (10 m/s)*
Repeatability	± 0,4 % of the measured value*

* determined in the following reference conditions: medium = water, water and ambient temperatures 20 °C, min. upstream and downstream distances respected, appropriate pipe dimensions.

Materials

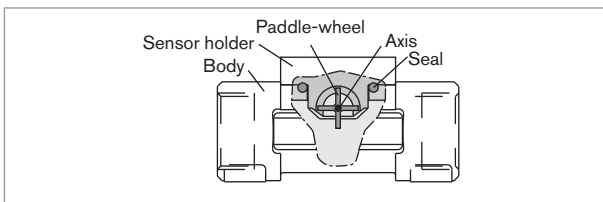

Fig. 1: Sectional drawing of the S030 HT fitting

Component	Material
Seal	FKM EPDM on request
Body	Stainless steel (316L - 1.4404)
Screws	Stainless steel (316L - 1.4404)
Paddle-wheel	Stainless steel
Axis	Ceramics (Al ₂ O ₃)
Bearings	Iglidur®

Dimensions of device

→ Please refer to the technical data sheets regarding the type 8030 HT available at: www.burkert.com

K factors (pulse/litre)

The K factors have all been determined under the following reference conditions: medium = water, water and ambient temperatures 20 °C, min. upstream and downstream distances respected, appropriate pipe dimensions.



To convert a K factor given in pulse/litre, use one of the following formulae:

K factor in pulse/US gallon = K factor in pulse/litre x 3.785 to obtain a flow rate value in US gallon/time unit

K factor in pulse/UK gallon = K factor in pulse/litre x 4,546 to obtain a flow rate value in UK gallon/time unit

! Two versions of the S030 HT in DN15 and DN20 exist, having different K factors.
Only version 2, identified by the "v2" marking, is available from March 2012. The "v2" marking can be found on the side of the DN15 or DN20 fitting in metal:

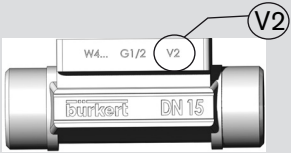

! If the fitting is combined with an SE30 HT electronic module in the sinus version, increase the given K factor by a factor of 2.

! The names of the following norms have changed in the Operating Instructions:

- for the welding ends, norm BS 4825 is renamed BS 4825-1.
- for the clamp connections, norm BS 4825 is renamed BS 4825-3.
- for the flange connections, norm EN 1092-1 is renamed EN 1092-1/B1.

!

- The norm for the clamp connections ISO has been replaced by norm DIN 32676 serie B.
- The norm for the clamp connections, DIN 32676 serie A has been added.

Type of connections and standard	K factors (pulse/litre)		
	DN6	DN8	DN15
Weld ends acc. to:			
▪ SMS 3008	-	-	-
▪ DIN 11866 serie C / BS 4825-1 / ASME BPE	-	-	-
▪ DIN 11850 serie 2 / DIN 11866 serie A / EN 10357 serie A	-	278	106
▪ DIN 11866 serie B / ISO 1127 / ISO 4200	-	-	106
External threads acc. to:			
▪ SMS 1145	-	-	-
▪ G	440	278	106
Internal threads acc. to:			
▪ G, Rc, NPT	-	-	106

K factors (pulse/litre)						
DN15 v2 ¹⁾	DN20	DN20 v2 ¹⁾	DN25	DN32	DN40	DN50
-	-	-	66,9	-	31,1	19,9
-	106	73,0	66,9	49,0	31,1	19,9
73,0	106	73,0	66,9	49,0	31,1	19,9
73,0	66,5	-	49,0	31,8	19,8	11,4
External threads acc. to:						
-	-	-	66,9	-	31,1	19,9
73,0	66,5	-	49,0	31,8	19,8	11,4
Internal threads acc. to:						
73,0	66,5	-	49,0	31,8	19,8	11,4

¹⁾ See page 16

Type of connections and standard	K factors (pulse/litre)		
	DN6	DN8	DN15
Clamp acc. to:			
▪ SMS 3017 / ISO 2852	-	-	-
▪ BS 4825-3 / ASME BPE	-	-	-
▪ DIN 32676 series A	-	278	106
▪ DIN 32676 series B	-	-	106
Flanges acc. to:			
▪ EN 1092-1 / B1 / PN16	440	-	106
▪ ANSI B16-5			
▪ JIS 10K			

K factors (pulse/litre)						
DN15 v2 ¹⁾	DN20	DN20 v2 ¹⁾	DN25	DN32	DN40	DN50
-	-	-	66,9	-	31,1	19,9
-	106	73,0	66,9	-	31,1	19,9
73,0	106	73,0	66,9	-	31,1	19,9
73,0	66,5	-	49,0	31,8	19,8	11,4
73,0	66,5	-	49,0	31,8	19,8	11,4

¹⁾ See page 16

7. INSTALLATION

Safety instructions

 **DANGER**

Risk of injury due to high pressure in the installation.

- Stop the circulation of fluid, cut-off the pressure and drain the pipe before loosening the process connections.

Risk of injury due to high fluid temperatures.

- Use safety gloves to handle the fitting.
- Stop the circulation of fluid and drain the pipe before loosening the process connections.

Risk of injury due to the nature of the fluid.

- Respect the prevailing regulations on accident prevention and safety relating to the use of hazardous products.

 **WARNING**

Risk of injury due to non-conforming installation.

- Fluidic installation can only be carried out by qualified and authorised personnel with the appropriate tools.
- Observe the installation instructions for the measuring device inserted into the fitting.

Risk of injury due to an uncontrolled restart.

- Ensure that the restart of the installation is controlled after any interventions on it.

 **WARNING**

Risk of injury if the fluid pressure / temperature dependency is not respected.

- Take into account the fluid pressure/ temperature dependency according to the materials from which the fitting is made and to the measuring device used (see the relevant user manual).
- Comply with the pressure equipment directive 97/23/EC.

→ Select an appropriate fitting regarding to the flow velocity and the flow rate of the fluid in the piping, see the following charts:

The graph is used to determine the DN of the pipe and the fitting appropriate to the application, according to the fluid velocity and the flow rate.

Selection example:

- Specification: if the nominal flow is 10 m³/h, the dimensioning of the optimal flow rate must be contained in 2 to 3 m/s
- Answer: on the chart, the intersection of flow rate and flow velocity gives the appropriate diameter, DN40 or DN50 for fittings with *.

* For fittings:

- with external threads according to SMS 1145
- with weld ends according to SMS 3008, BS 4825-1 / ASME BPE, DIN 11866 series C, DIN 11850 series 2 / DIN 11866 series A / EN 10357 series A
- Clamp according to SMS 3017 / ISO 2852, BS 4825-3 / ASME BPE, DIN 32676 series A

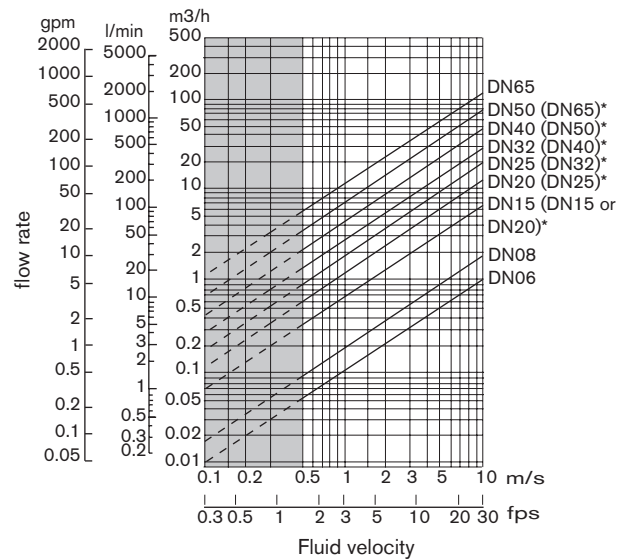

! To reduce the water hammer effects, install a special device such as an 80 bar calibrated exhaust valve within the circuit.

→ Install the fitting on the pipe to comply with the upstream and downstream distances defined by standard EN ISO 5167-1 (see Fig. 2).

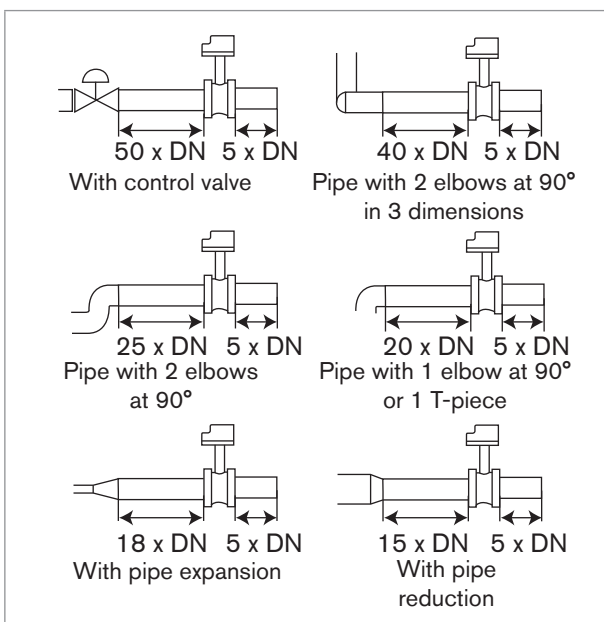

Fig. 2: Upstream and downstream distances depending on the design of the pipes.

→ Use a flow conditioner, if necessary, to obtain the best accuracy.

→ Prevent the formation of air bubbles in the pipe (see Fig. 3).

→ Ensure the pipe is always filled with liquid (see Fig. 4).

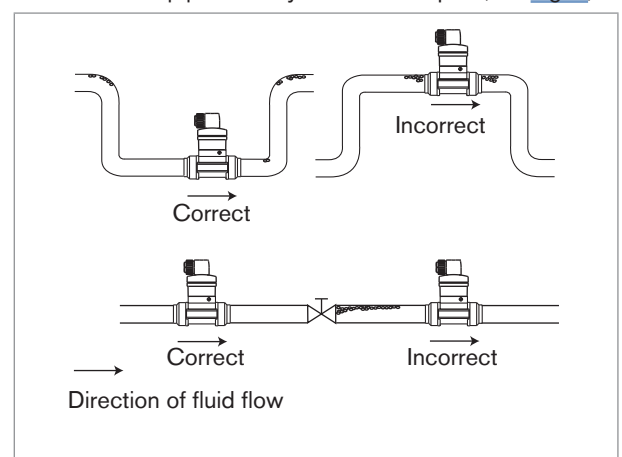

Fig. 3: Additional recommendations on installation

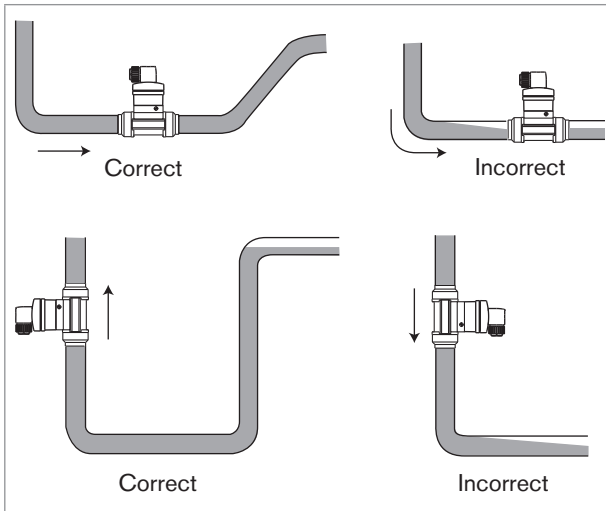

Fig. 4: Additional recommendations on installation

Installing a fitting with weld ends



Follow the previously described general installation recommendations.

NOTE

The seal on the fitting with weld-end connections may be damaged during welding.

- Before welding the weld-ends, unscrew the 4 tightening screws.
- Remove the sensor holder.
- Remove the seal.
- Weld the weld-ends.
- After welding, correctly replace the seal in the groove.
- Replace the sensor holder.
- Tighten the 4 screws in an alternating pattern, applying a nominal tightening torque of 1,5 Nm.

8. MAINTENANCE

Safety instructions



DANGER

Risk of injury due to high pressure in the installation.

- Stop the circulation of fluid, cut-off the pressure and drain the pipe before loosening the process connections.

Risk of injury due to high fluid temperatures.

- Use safety gloves to handle the fitting.
- Stop the circulation of fluid and drain the pipe before loosening the process connections.
- Keep all easily flammable fluid or material away from the fitting.

Risk of injury due to the nature of the fluid.

- Respect the prevailing regulations on accident prevention and safety relating to the use of aggressive fluids.



WARNING

Risk of injury due to non-conforming maintenance.

- Maintenance must only be carried out by qualified and skilled staff with the appropriate tools.
- Ensure that the restart of the installation is controlled after any interventions.

Cleaning

NOTE

The fitting may be damaged by the cleaning product.

- Clean the fitting with a cloth dampened with water or a detergent compatible with the materials the fitting is made of.

9. SPARE PARTS AND ACCESSORIES



ATTENTION

Risk of injury and/or damage caused by the use of unsuitable parts.

Incorrect accessories and unsuitable spare parts may cause injuries and damage the fitting and the surrounding area.

- Use only original accessories and original spare parts from Bürkert.



Two versions of the S030 HT in DN15 and DN20 exist, having different K factors.

Only version 2, identified by the "v2" marking, is available from March 2012. The "v2" marking can be found on the side of the DN15 or DN20 fitting in metal:

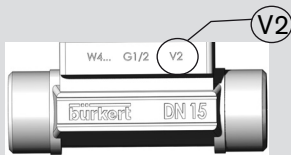

Spare parts	Order code
Sensor holder in stainless steel	
With stainless steel paddle-wheel, FKM seal, screws and certificate, for DN06, DN08, DN15 v2 and DN20 v2	449 723
With stainless steel paddle-wheel, FKM seal, screws and certificate, for DN15 (except DN15 v2 and DN20 v2) to DN50	551 764
With stainless steel paddle-wheel, EPDM seal, screws and certificate, for DN06, DN08, DN15 v2 and DN20 v2	449 724
With stainless steel paddle-wheel, EPDM seal, screws and certificate, for DN15 (except DN15 v2 and DN20 v2) to DN50	551 763
Set of O-rings (DN6 to DN50) for metal fittings (see Fig. 5)	
FKM	426 340
EPDM	426 341



Fig. 5: Position of O-ring in an S030 HT fitting

Accessory	Order code
Inspection certificate 3.1 acc. to EN 10204	803 723
Test report 2.2 acc. to EN 10204	803 722
Certificate with the surface finish value	804 175
3-point calibration certificate (S030 HT combined with the flowmeter inserted)	550 676

10. PACKAGING, TRANSPORT, STORAGE

ATTENTION

Damage due to transport

Transport may damage an insufficiently protected part.

- Transport the fitting in shock-resistant packaging and away from humidity and dirt.
- Do not expose the fitting to temperatures that may exceed the admissible storage temperature range.

Poor storage can damage the fitting.

- Store the fitting in a dry place away from dust.
- Storage temperature: -15 to +100 °C.

Damage to the environment caused by products contaminated by fluids.

- Dispose of the fitting and its packaging in an environmentally-friendly way.
- Keep to the existing provisions on the subject of waste disposal and environmental protection.