

ITEM NUMBER	BAG SIZE	A IN. / MM	B IN. / MM	C IN. / MM	D IN. / MM	E IN. / MM	F IN. / MM	G IN. / MM	H IN. / MM	J IN. / MM	K IN. / MM	L IN. / MM	WEIGHT LBS / KGS
F3AVTB0222	02	5 / 127	30-3/4 / 781	36-1/2 / 927	51-3/8 / 1305	62-3/4 / 1594	19-1/4 / 489	8-5/8 / 219	12-1/8 / 308	24-1/2 / 622	37-1/2 / 952.5	18-3/4 / 476.2	290 / 131

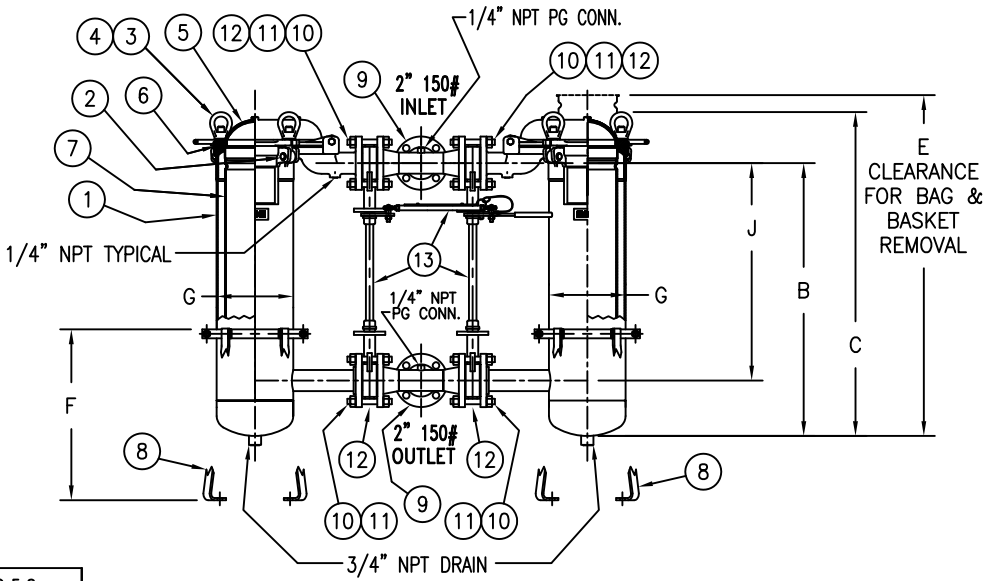
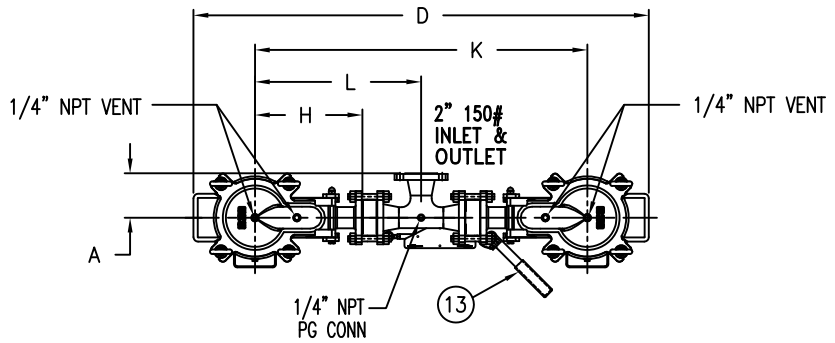
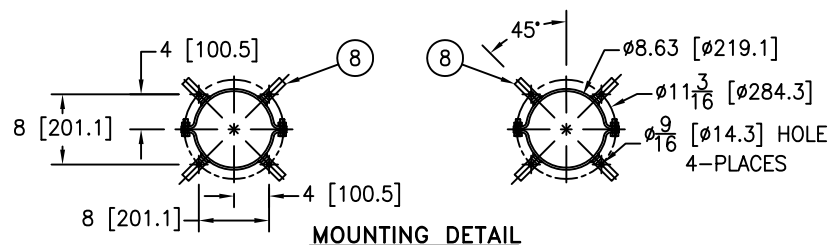

REVISIONS				
REV	DESCRIPTION	BY	ECO	DATE
C	UPDATED DRAWING	FJM	0087416	07/18/13

NO.	PART NAME	MATERIAL
1	BODY	SA-351 CF8M SA-312 TP 316 SA-403 TP 316
2	PIN	SA-193 GR B7, ZINC PL
3	EYE BOLT	SA-193 GR B7, ZINC PL
4	EYE NUT	SA-194 GR 2H, ZINC PL
5	COVER	SA-351 CF8M
6	O-RINGS (2) P/N 811333 & L0000024	BUNA-N
7	RESTRAINER BASKET P/N L0001753	316 STAINLESS STEEL
8	ADJUSTABLE LEGS	CSTL EPOXY COATED
9	INLET/OUTLET MANIFOLDS	316 STAINLESS STEEL
10	STUDS	SA-193 GR B7, ZINC PL
11	NUTS	SA-194 GR 2H, ZINC PL
12	BUTTERFLY VALVE 2" 150# WAFER STYLE NO HANDLE	CAST OR DUCTILE IRON BODY SSTL DISC & SHAFT BUNA-N SEAT
13	VALVE LINKAGE W/HANDLE	304 STAINLESS STEEL

- NOTES:**
- UNITS ARE TO BE DESIGNED, FABRICATED & "UM" STAMPED IN ACCORDANCE WITH ASME SECT. VIII, DIV. 1 BOILER & PRESSURE VESSEL CODE, IN COMPLIANCE TO LATEST ADDENDA.
 - INLET/OUTLET FLANGED CONNECTIONS PER ANSI B16.5.
 - MAWP: 150 PSI @ 250° F (10.3 BAR @ 121.1° C) MDMT: -20° F @ 150 PSI (-28.9° C @ 10.3 BAR)
 - MAXIMUM OPERATING TEMP. 400° F (204.4° C) WITH VITON O-RING & VITON BUTTERFLY VALVE SEATS.
 - DIMENSIONS SHOWN IN [] ARE IN MILLIMETERS AND FOR REFERENCE ONLY. ACCEPTANCE OF THIS PART WILL BE BASED ON "INCH" UNITS & TOLERANCES ONLY.

TOLERANCES (UNLESS OTHERWISE SPECIFIED)	
DECIMAL:	.X ± .030 .XX ± .010 .XXX ± .005
FRACTIONAL:	± 1/16
NOZZLE Ø TO FLOOR:	1/8" < 4' > 1/4"
FACE TO FACE:	1/8" < 4' > 1/4"
ANGULAR:	± 1'
FLANGES (H/V):	± 1/2"
VESSEL OVERALL HT:	1"

REVIEWED FOR CLASSIFICATION PER PR-4
 CRITICAL SIGNIFICANT

CUSTOMER INFO	
NAME	
P.O. NO.	
S.O. NO.	
QUANTITY	
PART NO.	F3AVTB0222

DRAWN BY	FJM
SCALE	AS DRAWN
RESTRICTION	RESTRICTION
SHEET	1 OF 1
PROJECTION	THIRD ANGLE

VESSEL CODE: DTBF-0102-AB10-020A-LINK			
		EATON FILTRATION, LLC DESIGN CENTER TINTON FALLS, NEW JERSEY, USA PORTAGE, MICHIGAN, USA	
TITLE TOPLINE (DTBF) DUPLEX BAG FILTER 2" 150# RF FLANGED CONNECTIONS SSTL W/ BUTTERFLY VALVES LINKED, MANIFOLDS & BUNA O-RINGS			
DATE	SIZE	DWG FILENAME	REV
06/12/03	A	DTBF02XS-2KL	C

EATON CORPORATION - CONFIDENTIAL AND PROPRIETARY NOTICE TO PERSONS RECEIVING THIS DRAWING AND/OR TECHNICAL INFORMATION THIS DOCUMENT, INCLUDING THE DRAWING AND INFORMATION CONTAINED THEREON IS CONFIDENTIAL AND IS THE EXCLUSIVE PROPERTY OF EATON AT ANY TIME. BY TAKING THE POSSESSION OF THIS DOCUMENT THE RECIPIENT ACKNOWLEDGES AND AGREES THAT THIS DOCUMENT CANNOT BE USED IN ANY MANNER ADVERSE TO THE INTEREST OF EATON AND THAT NO PORTION OF THIS DRAWING MAY BE COPIED OR OTHERWISE REPRODUCED WITHOUT THE PRIOR WRITTEN CONSENT OF EATON. IN THE CASE OF CONFLICTION CONTRACTUAL PROVISIONS, THIS NOTICE SHALL GOVERN THE STATUS OF THIS DOCUMENT.
 2013 EATON CORPORATION - ALL RIGHTS RESERVED.