



LV & EZ Series

"LV" & "EZ" Series.....	G36	"EZ" Series	
"LV" Series		Basic Features	G41
Basic Features	G37	Applications	G41
Applications	G37	Mounting.....	G41
Mounting.....	G37	Dimensions.....	G41
Ordering Information	G38	Operation.....	G42
Dimensions		Ordering Information	G42
Compact	G39	Flow	G43
Standard	G39	"LV" & "EZ" Series Accessories	G43
High Flow.....	G39		
Stainless Steel.....	G40		

G
Airline Accessories

Bold Items are Most Popular.

Parker is protecting your most valuable assets...

 <p>Standard 190.147</p>	<ul style="list-style-type: none"> • This applies to the servicing and maintenance of a machine or equipment. • Any new, replacement, repair, or renovation to a machine must include an energy isolation device that can accept a lock out device. • Lock out devices should not be used for any other purposes • Verification of energy isolation is required
---	---

 <p>Standard Z244</p>	<ul style="list-style-type: none"> • This applies to all machines • Lockout / tagout is the primary method of hazardous energy control • Machines shall be designed, manufactured, supplied, and installed with energy isolating devices
--	---

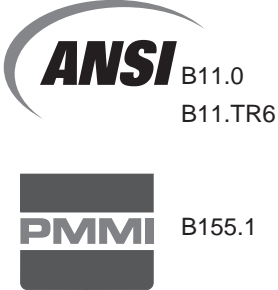
	<ul style="list-style-type: none"> • B11.0 applies to a broad range of machines, B11.TR6 is specific to machine tools, and B155.1 is specific to packaging and converting machines • Energy isolating device shall: <ul style="list-style-type: none"> – Be capable of being locked in the OFF position only – Be easy to operate – Have an exhaust port equal or greater than its supply port – Have a pressure indicator that is visible to an operator to verify line is relieved of pressure
--	---

...By offering the best in pneumatic safety for machine maintenance:

G
Airline Accessories



Traditional Ball Valve

- Not a dedicated energy isolation device
- Not a full exhaust port
- No verification of line exhaust
- Can be locked ON
- Not easily identifiable



Wilkerson Solution

- ✓ **Dedicated energy isolation device**
- ✓ Full exhaust port
- ✓ Verification of line exhaust
- ✓ Only lockable in OFF position
- ✓ Easily identifiable

LV Series

Features

Lockout valves are installed in pneumatic drop legs, or individual pneumatic control lines. In accordance with OSHA procedures, lockout valves are used during maintenance and service procedures of pneumatically (air) operated equipment.

- Used for compliance with OSHA 29 CFR part 1910
- 1/4" to 2" pipe sizes. NPT or BSPP
- Yellow cast aluminum body with red handle or stainless steel (NACE MR0175 / ISO 15156)
- Inline or surface mountable
- Built in port for pressure verification to meet ANSI B11 and PMMI B155 requirements
- Fluorocarbon slipper seals for easy shifting, even after long periods of inactivity

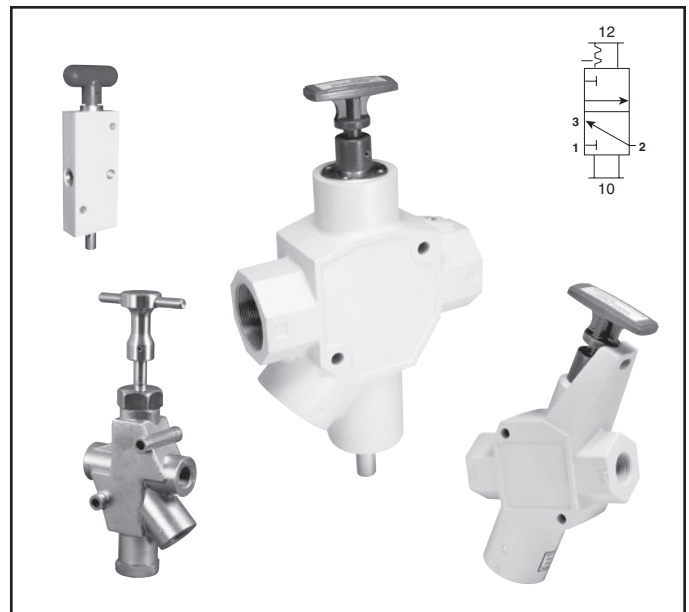

Material Specifications

Description	LV	LVSS
Body:	Cast aluminum alloy	Stainless steel
Handle:	Plastic	Stainless steel
Spool:	Aluminum	Stainless steel
Seals:	Carboxylated nitrile	Fluorocarbon
Detent spring:	Stainless steel	316 Stainless steel
Grease:	Magnalube G †	Magnalube G †

† Trademark Magnalube

Operating Information

Operating pressure:	LV	LVSS
Compact	15 to 145 PSIG	–
Standard	15 to 300 PSIG	15 to 300 PSIG
High flow	15 to 300 PSIG	–
Operating temperature:	40°F to 175°F	30°F to 175°F
Operating media:	Clean, dry, compressed air (5 micron)	

Applications

Lockout valves are installed in pneumatic drop legs, or individual pneumatic control lines (see Figure 1). In accordance with OSHA procedures, lockout valves are used during maintenance and service procedures of pneumatically (air) operated equipment. Prior to servicing, the red handle is pressed inward, blocking pressure and relieving all downstream air pressure. A padlock is installed through the locking hasp, preventing accidental actuation during the maintenance procedure. Following maintenance, the padlock is removed and the red handle is pulled outward, returning air pressure to the system.

(For complete Lockout / Tagout procedures, consult OSHA Standard 29 CFR Part 1910 in U.S. Federal Register/Vol. 54 No. 169, Friday, September 1, 1989 / Page 36644.)

Mounting

Valves can be inline mounted or surface mounted using the two mounting holes provided in the valve body. Mount valves in plain view with the handle oriented for accessibility.

Placement of Lockout Device

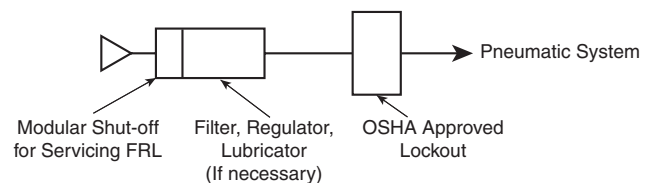



Figure 1.

Compact

	Port in / out	Port exhaust	Wt (lb)	Part number *
	1/4	3/8	0.9	LV2N3B
	3/8	3/8	0.9	LV3N3B

Standard

	Port in / out	Port exhaust	Wt (lb)	Part number *
	3/8	3/4	2.0	LV3N6B
	1/2	3/4	2.0	LV4N6B
	3/4	3/4	2.0	LV6N6B
	3/4	1-1/4	3.2	LV6NAB
	1	1-1/4	3.2	LV8NAB
	1-1/4	1-1/4	3.2	LVANAB

High Flow

	Port in / out	Port exhaust	Wt (lb)	Part number *
	1-1/2	2	8.2	LVBNCB
	2	2	8.2	LVCNCB

Stainless Steel

	Port in / out	Port exhaust	Wt (lb)	Part number *
	1/4	1/4	3.8	LV2N2BSS
	3/8	1/2	6.0	LV3N4BSS
	1/2	1/2	6.0	LV4N4BSS
	3/4	1	13	LV6N8BSS
	1	1	13	LV8N8BSS
	1-1/2	2	35	LVBNCBSS
	2	2	35	LVCNCBSS

* For BSPP ports, change 4th digit from "N" to "B"

Operation

Normal Machine Operation – Valve Open

With the handle pulled outward. Inlet Port 1 is open to outlet Port 2. Exhaust Port 3 is blocked.

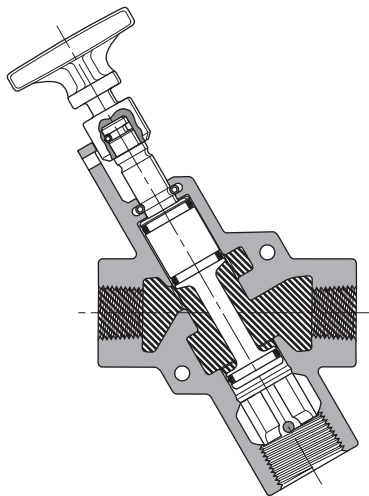

LV Series Shown Open

Lockout Operation – Valve Closed

With the handle pushed inward. Inlet Port 1 is blocked. Outlet Port 2 is open to Exhaust Port 3.

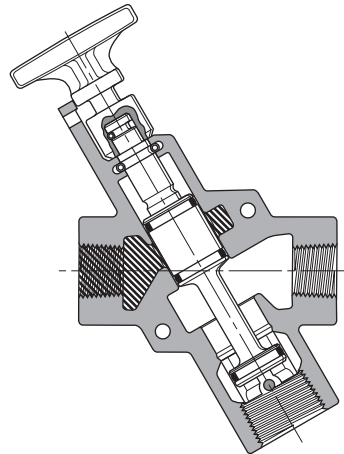

LV Series Shown Closed

LV Dimensions

Compact

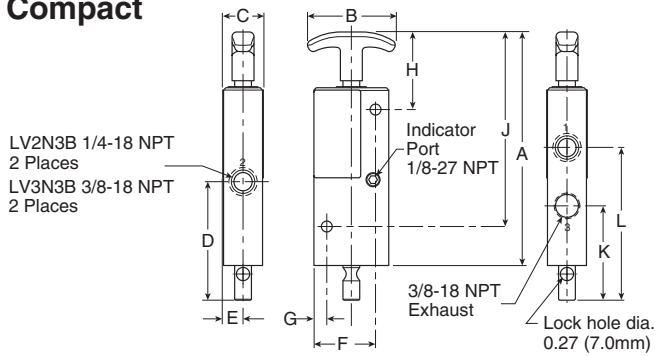

Compact LV Series, 3/8" Exhaust Ports Inches (mm)

A 6.50 (165)	B 2.25 (57)	C 1.05 (27)	D 3.04 (77)	E .51 (13)	F 1.58 (40)
G .33 (8)	H 1.99 (51)	J 4.99 (127)	K 2.42 (62)	L 3.92 (100)	

Standard

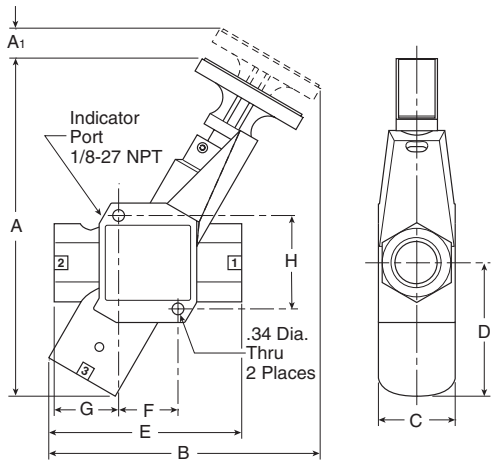

Standard LV Series, 3/4" Exhaust Port Inches (mm)

A 8.32 (211)	A1 0.64 (16)	B 6.60 (168)	C 2.00 (51)	D 3.06 (78)	E 4.24 (108)
F 1.32 (111)	G 1.56 (40)	H 2.21 (56)			

Standard LV Series, 1-1/4" Exhaust Port Inches (mm)

A 9.91 (252)	A1 0.85 (22)	B 7.95 (202)	C 2.25 (57)	D 3.91 (99)	E 5.65 (144)
F 1.74 (44)	G 1.89 (48)	H 2.74 (70)			

High Flow

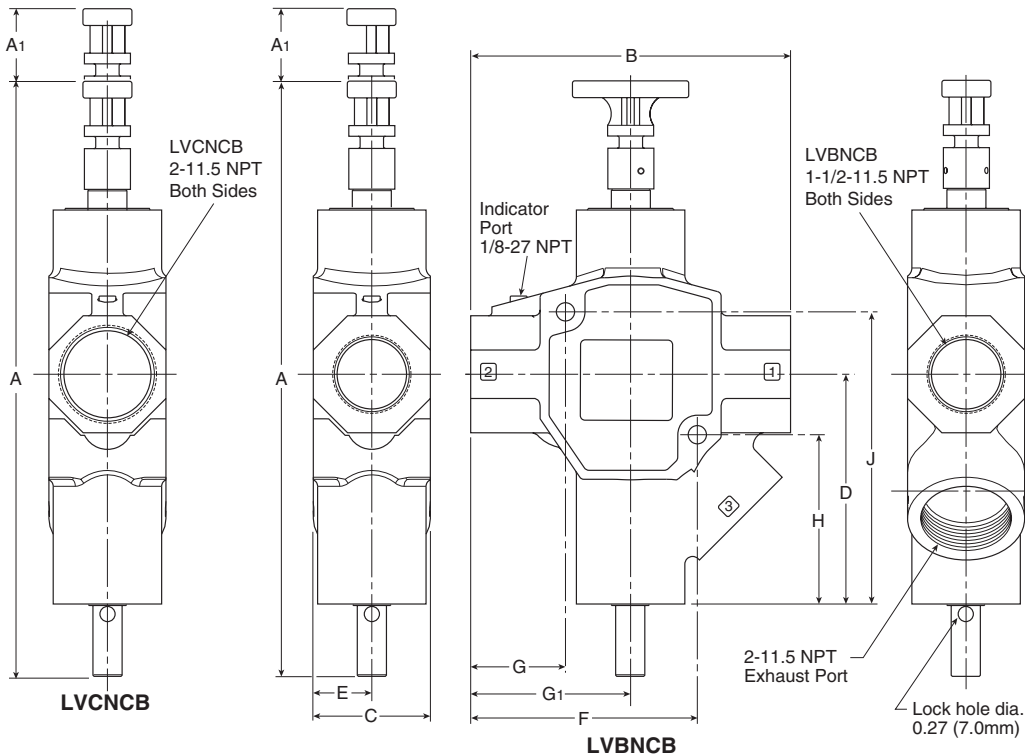

High Flow LV Series, 2" Exhaust Ports Inches (mm)

A 14.82 (376)	A1 1.87 (47)
B 8.20 (208)	C 3.00 (76)
D 5.89 (150)	E 1.50 (38)
F 5.81 (148)	G 2.43 (62)
G1 4.10 (104)	H 4.34 (110)
J 7.49 (190)	

G

Airline Accessories

Stainless Steel Dimensions

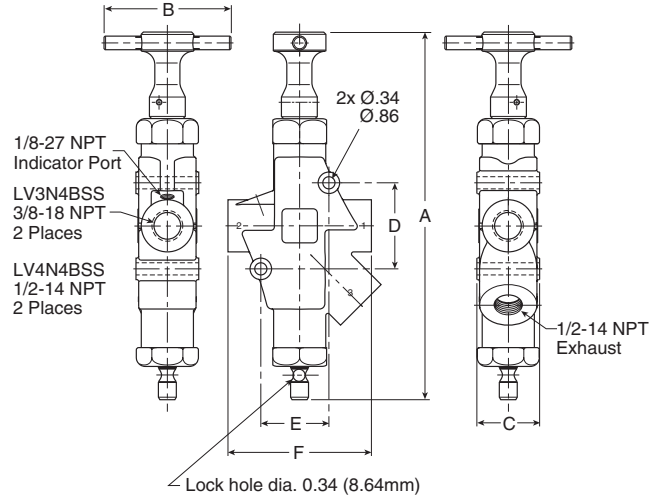
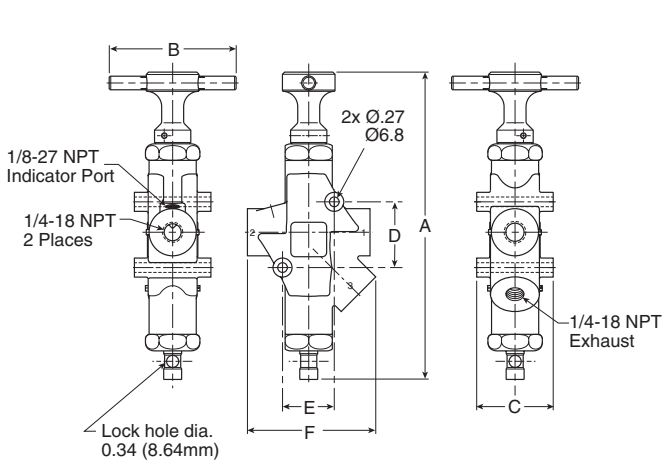

Stainless Steel LV Series, 1/4" Exhaust Port inches (mm)

A	B	C	D	E	F
8.47 (215)	3.50 (89)	2.11 (54)	1.81 (46)	1.43 (36)	3.54 (90)

Stainless Steel LV Series, 1/2" Exhaust Port inches (mm)

A	B	C	D	E	F
10.24 (260)	3.50 (89)	1.75 (45)	2.40 (61)	1.90 (48)	4.00 (102)

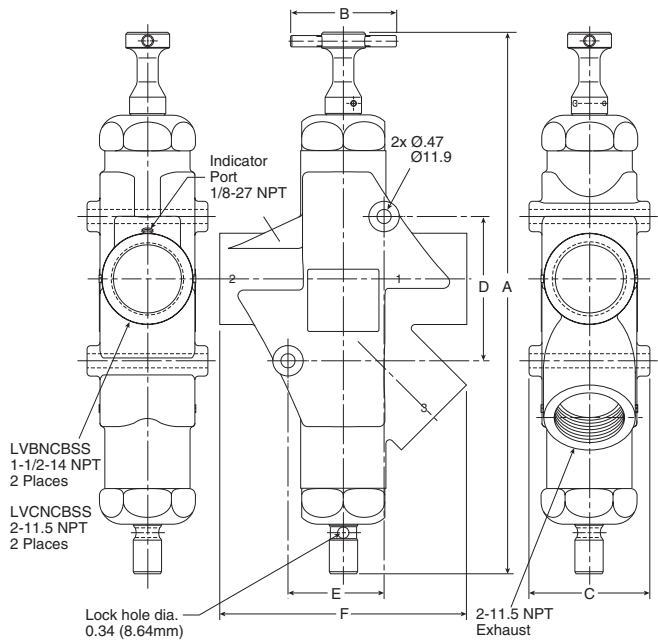
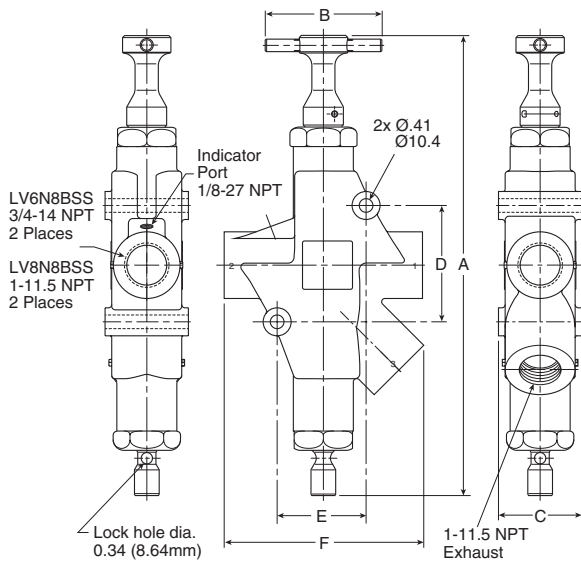

Stainless Steel LV Series, 1" Exhaust Port inches (mm)

A	B	C	D	E	F
13.80 (351)	3.50 (89)	2.50 (64)	3.49 (89)	2.67 (68)	5.99 (152)

Stainless Steel LV Series, 2" Exhaust Port inches (mm)

A	B	C	D	E	F
17.92 (455)	3.50 (89)	4.00 (102)	4.77 (121)	3.18 (81)	8.16 (207)

G

Airline Accessories

EZ Series

Features

- Combines lockout and soft-start functions in a single unit
- Used in systems for compliance with OSHA standard 29 CFR part 1910
- 3/8 Inch to 1-1/4 inch pipe sizes
- Cv's from 3.7 To 13.7
- 3/4 and 1-1/4 inch: exhaust ports available
- Exhaust port threaded for installation of silencer or line for remote exhausting
- Inline or surface mountable
- Yellow cast aluminum body with red handle. Blue dot on body indicates EZ Series valve
- Fluorocarbon slipper seals for easy shifting, even after long periods of inactivity

Material Specifications

Description	EZ
Body:	Cast aluminum alloy
Handle:	Plastic
Spool:	Aluminum
Seals:	Carboxylated nitrile
Detent spring:	Stainless steel
Grease:	Magnalube G [†]

[†] Trademark Magnalube

Applications

EZ valves are installed in pneumatic drop legs, or individual pneumatic control lines (see Figure 1). In accordance with OSHA procedures, EZ valves are used during maintenance and service procedures of pneumatically (air) operated equipment. Prior to servicing, the red handle is pressed inward, blocking pressure and relieving all downstream air pressure. A padlock is installed through the locking hasp, preventing accidental actuation during the maintenance procedure. Following maintenance, the padlock is removed and the red handle is pulled outward, gradually returning air pressure to the system. (For complete Lockout / Tagout procedures, consult OSHA Standard 29 CFR Part 1910 in U.S. Federal Register/Vol. 54 No. 169, Friday, September 1, 1989 / Page 36644.)

Mounting

Valves can be inline mounted or surface mounted using the two 11/32" mounting holes provided in the valve body. Mount valves in plain view with the handle oriented for accessibility.

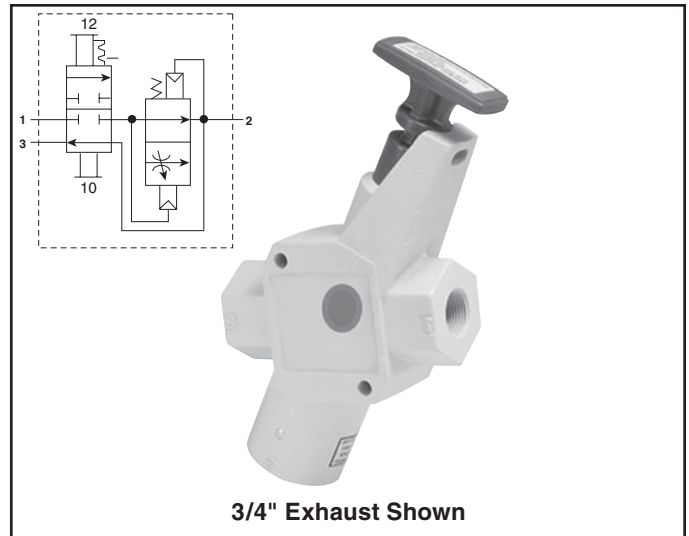

Operating Information	
Operating pressure:	15 to 300 PSIG
Operating temperature:	40°F to 175°F
Operating media:	Clean, dry, compressed air (5 micron)

EZ Dimensions

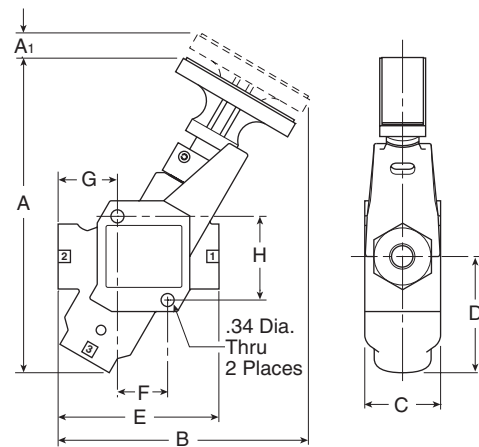

EZ Series, 3/4" Exhaust Port Inches (mm)

A	A1	B	C	D	E
8.32 (211)	0.64 (16)	6.60 (168)	2.00 (51)	3.06 (78)	4.24 (108)
F	G	H			
1.32 (111)	1.56 (40)	2.21 (56)			

EZ Series, 1-1/4" Exhaust Port Inches (mm)

A	A1	B	C	D	E
9.91 (252)	0.85 (22)	7.95 (202)	2.25 (57)	3.91 (99)	5.65 (144)
F	G	H			
1.74 (44)	1.89 (48)	2.74 (70)			

EZ Series

	Port in / out	Port exhaust	Wt (lb)	Part Number *
	3/8	3/4	2.1	EZ03NB6
	1/2	3/4	2.1	EZ04NB6
	3/4	3/4	2.1	EZ06NB6
	3/4	1-1/4	3.2	EZ06NBA
	1	1-1/4	3.2	EZ08NBA
	1-1/4	1-1/4	3.2	EZ0ANBA

* For BSPP ports, change 5th digit from "N" to "B"

Operation

Normal Machine Operation – Valve Open

When the red handle is pulled outward, the adjustable needle valve (accessed through the top of the handle) setting determines the rate of pressure buildup. When downstream pressure reaches the full flow described in the specifications below, Inlet Port 1 is open to outlet Port 2. Exhaust Port 3 is blocked.

Lockout Operation – Valve Closed

When the red handle is pushed inward, the Inlet Port 1 is blocked. Downstream air is exhausted through Exhaust Port 3.

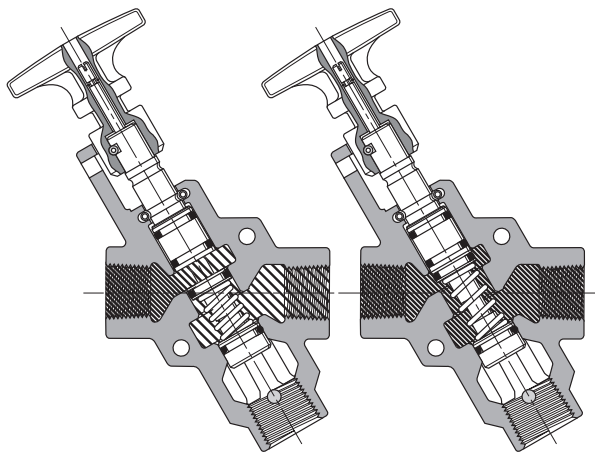

Open
Pressure Building Up

Open
Full Flow

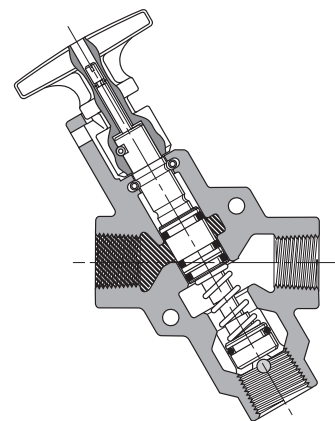

Closed

G

Airline Accessories

Flow

Compact LV Series Part Number	Port In / Out	scfm In / Out	Port Exh	scfm Exh
LV2N3B	1/4	41.8	3/8	40.7
LV3N3B	3/8	60.7	3/8	60.7

Standard LV Series Part Number	Port In / Out	scfm In / Out	Port Exh	scfm Exh
LV3N6B	3/8	107.7	3/4	81.1
LV4N6B	1/2	161.4	3/4	90.9
LV6N6B	3/4	187.7	3/4	93.2
LV6NAB	3/4	297.7	1-1/4	204
LV8NAB	1	375	1-1/4	216
LVANAB	1-1/4	436.4	1-1/4	221

High Flow LV Series Part Number	Port In / Out	scfm In / Out	Port Exh	scfm Exh
LVBNCB	1-1/2	761.4	2	1156
LVCNCB	2	918.2	2	1186

EZ Series Part Number	Port In / Out	scfm In / Out	Port Exh	scfm Exh
EZ03NB6	3/8	136.4	3/4	181
EZ04NB6	1/2	161.4	3/4	189
EZ06NB6	3/4	181.9	3/4	216
EZ06NBA	3/4	272.7	1-1/4	248
EZ08NBA	1	311.4	1-1/4	273
EZ0ANBA	1-1/4	368.2	1-1/4	291

Stainless LV Series Part Number	Port In / Out	scfm In / Out	Port Exh	scfm Exh
LV2N2BSS	1/4	48.6	1/4	47.2
LV3N4BSS	3/8	131.6	1/2	142
LV4N4BSS	1/2	124.8	1/2	142
LV6N8BSS	3/4	325	1	386
LV8N8BSS	1	325	1	386
LVBNCBSS	1-1/2	889	2	1023
LVCNCBSS	2	889	2	1023

NOTE: Exhaust flow rates calculated using inlet pressure 100 psig (6.7 bar), pressure drop 5 psi (0.34 bar), air temp 68°F (20°C), and 36% relative humidity.

LV / EZ Accessories

Corrosion resistant mufflers for harsh environments

Port Size	Construction	Threads*	Dimensions In. (mm)		Part Number
			Width	Length	
1/4	Stainless steel	Male	0.56 (14.2)	1.75 (44.5)	5500A2004
1/2	Stainless steel	Male	0.87 (22.1)	2.75 (69.7)	5500A4004
1	Stainless steel	Male	1.31 (33.3)	3.87 (98.3)	5500A6004
2	Nickel plated	Male	2.37 (60.2)	5.50 (139.7)	5500A9004

* NPT threads only

High Flow Silencers

Part Number *	ES25MC	ES37MC	ES50MC	ES75MC	ES100MC	ES125MC	ES150MC	ES200MC
Pipe size	1/4	3/8	1/2	3/4	1	1-1/4	1-1/2	2
Flow (scfm)	129	219	549	893	1013	1486	1580	1580
Hex In. (mm)	0.63 (16)	1.00 (25)	1.00 (25)	1.62 (41)	1.62 (41)	—	—	2.99 (76)
Length In. (mm)	1.85 (47)	3.31 (84)	3.31 (84)	4.56 (116)	4.56 (116)	5.69 (145)	5.69 (145)	7.68 (195)

* NPT ports standard, for BSPT ports, add a "B" after the "S"

Pop-up Pressure Indicator



Brass – Part # 988A30 – Can be used on all LV or EZ series to provide visual verification of line exhaust



Stainless – Part# 1155H30 – Can be used on SS LV series to provide visual verification of line exhaust

Pressure Switch



- Part # PPS1-2C3-RHM (DIN 9.4mm connector)
- Part # PPS1-2C3-RWL (18" leads)
- Signal verification of line exhaust
- Field adjustable set point