

REVISIONS

REV	DESCRIPTION	BY	ECO	DATE
C	NEW RELEASE	FM	0058909	7/14/2011
D	UPDATED TITLE BLOCK	S. PATIL	0112361	7/24/2015
E	CHANGED DIRECTION OF THE FLOW ARROW	N.INGOLE	0116455	10/30/2015

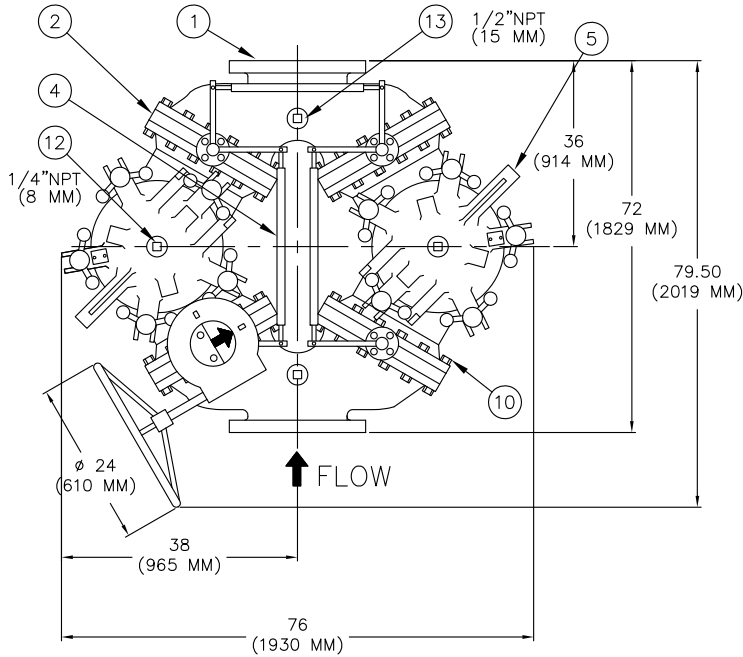

NOTE:

1. INLET/OUTLET FLANGE PER ASME B16.1 CLASS 125 FF FLANGE.
2. MAX. WORKING PRESS.: 150 PSI [10.3 BAR.] 100° F [37.8° C]
3. DIMENSIONS ARE IN INCHES / (MM)
4. WEIGHT: 4300 LBS. (1950 KG.)
5. HANDWHEEL LOCATED LEFT SIDE OF INLET.

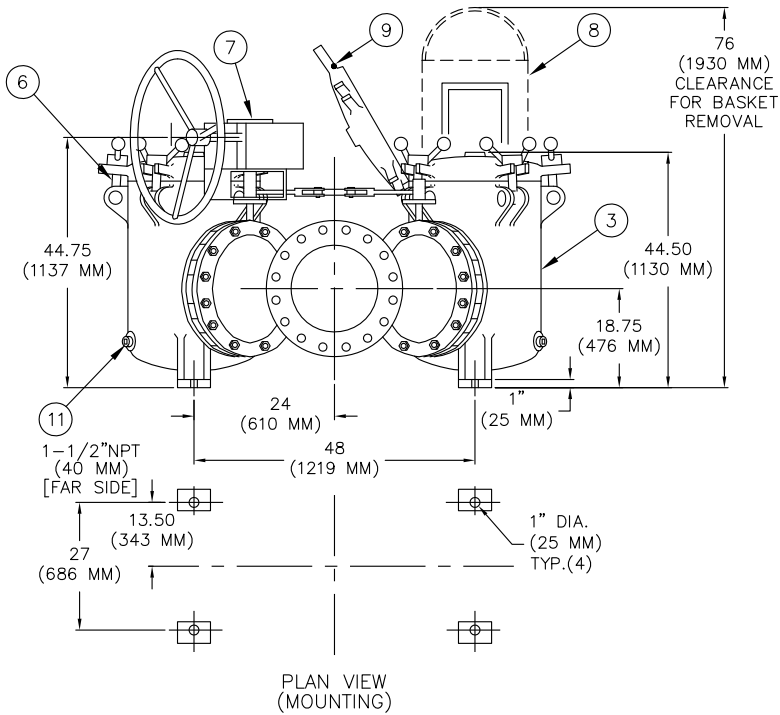

CAUTION:

DUE TO THE TYPE OF CONSTRUCTION OF THIS STRAINER, ALL DIMENSIONS MAY VARY PLUS OR MINUS 1.50% OF THE CHARTED FIGURES. THE CUSTOMER IS ADVISED NOT TO FABRICATE ADJOINING PIPING UNTIL RECEIPT OF THE UNIT AT THE JOB SITE.

13	PIPE PLUG (GAGE)	IRON
12	PIPE PLUG (VENT)	IRON
11	PIPE PLUG (DRAIN)	IRON
10	BOLT/NUT	CARBON STEEL
9	O-RING	BUNA-N
8	BASKET PERF. DIA. MESH SIZE	
7	GEAR OPERATOR	IRON
6	SWING BOLTS	CARBON STEEL
5	COVER	CAST IRON A126 CL.C
4	LINKAGE	STEEL
3	BODY	CAST IRON A126 CL.C
2	BUTTERFLY VALVE	IRON /BUNA-N SEAL
1	FLANGED Y	CAST IRON A126 CL.C
ITEM	DESCRIPTION	MATERIAL

PART LIST FOR:

DRAWN BY FM
SCALE AS DRAWN
RESTRICTION RESTRICTED
SHEET 1 OF 1
PROJECTION THIRD ANGLE

		HYDRAULICS GROUP	
		FILTRATION DIVISION	
		GALESBURG, MICHIGAN, USA • TINTON FALLS, NEW JERSEY, USA	
TITLE			
MODEL 52 DUPLEX STRAINER 125# FLAT FACE FLANGE			
SIZE 14" CAST IRON (HANDWHEEL ON INLET)			
DATE	SIZE	DWG FILENAME	REV
8/16/04	A	SD052111	E

CUSTOMER INFO	
NAME	
P.O. NO.	
TAG NO.	
S.O. NO.	
PART NO.	ST052140AF4026

EATON CORPORATION - CONFIDENTIAL AND PROPRIETARY NOTICE TO PERSONS RECEIVING THIS DRAWING AND/OR TECHNICAL INFORMATION. THIS DOCUMENT, INCLUDING THE DRAWING AND INFORMATION CONTAINED THEREON IS CONFIDENTIAL AND IS THE EXCLUSIVE PROPERTY OF EATON AT ANY TIME. BY TAKING THE POSSESSION OF THIS DOCUMENT THE RECIPIENT ACKNOWLEDGES AND AGREES THAT THIS DOCUMENT CANNOT BE USED IN ANY MANNER ADVERSE TO THE INTEREST OF EATON AND THAT NO PORTION OF THIS DRAWING MAY BE COPIED OR OTHERWISE REPRODUCED WITHOUT THE PRIOR WRITTEN CONSENT OF EATON, IN THE CASE OF CONFLICTING CONTRACTUAL PROVISIONS, THIS NOTICE SHALL GOVERN THE STATUS OF THIS DOCUMENT. 2015 EATON CORPORATION - ALL RIGHTS RESERVED.