

McGill™ 8700 AUTO-LOC Heavy Duty Cord Reels

NEC/CEC:
Listed for Ordinary Locations

Applications

- Weather-tight, dust-tight construction for heavy-duty industrial applications
- Ideal for hoists, electric tools, and moving equipment

Features

- Weather-tight, dust-tight construction for heavy-duty industrial applications.
- Corrosion resistant.
- Sufficient spring tension to provide no more than 10% sag when cable is stretched horizontally.
- Fully adjustable four roller cable guide to minimize cable wear.
- Long life, self-contained mainspring.
- Furnished with black SO cable up to 12 conductors.
- Removable ratchet for application flexibility.
- 30-75 Amp, 600 V modular collector ring designed for long service life.
- 330° pivot bases available for 2-6 conductor reels.
- 1" NPT line entry in junction box.

Standard Materials

- Heavy gauge steel/yellow powder polyester coat
- 8701-8712 die cast aluminum



NEC/CEC Certifications and Compliances

- 8706 and 8707 models are UL Listed: E53326
- UL Standard: 355
- 8706 and 8707 models are CSA Certified
- NEMA 4

SO Cord Type	Rating	Catalog Numbers		
		21.3 m (70') Cord	15.2 m (50') Cord	12.2 m (40') Cord
12/4	14 Amp	—	—	8707
12/3	18 Amp	8729	8706	—

Accessories and Replacement Parts

Description	Catalog Number
Ball stops For reels with 16 ga.; 14 ga. 3, 4, and 6 conductor; 12 ga. 3 and 4 conductor; 10/3 cord (cord dia. .430-.750")	8600-001

Dimensions in Millimeters (Inches)

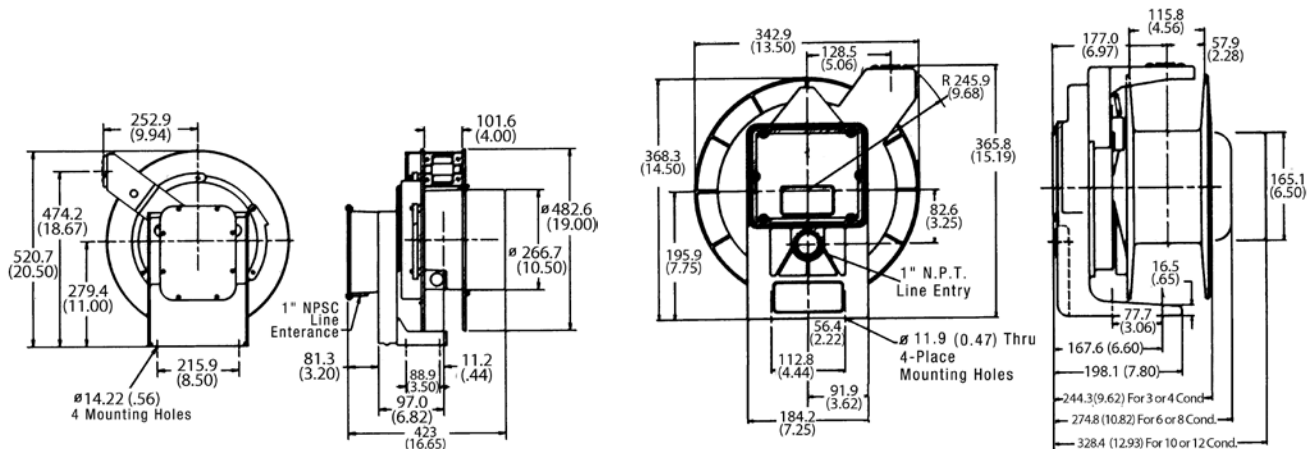

8701-8712 Series

8713-8747 Series

REELS AND SWITCHES/CORD AND CABLE REELS: WEATHER PROTECTED

Appleton OZGEDNEY