

PIPE SIZE (NOMINAL)	DIMENSIONS			APPROX. WEIGHT (DRY)	PART NO.
	"A"	"B"	"C"		
	IN. (MM)	IN. (MM)	IN. (MM)	LBS. (KGS)	
2 (50mm)	10.12 / 257	5.88 / 149	13.00 / 330	33 / 14.9	ST091020BR3BA
3 (80mm)	12.38 / 314	7.19 / 183	17.00 / 432	65 / 29.5	ST091030BR3BA
4 (100mm)	14.38 / 365	8.19 / 208	20.00 / 508	90 / 40.8	ST091040BR3BA
5 (125mm)	16.88 / 429	9.44 / 240	23.00 / 584	115 / 52.2	ST091050BR3BA
6 (150mm)	18.38 / 467	10.25 / 260	25.00 / 635	145 / 65.8	ST091060BR3BA
8 (200mm)	22.12 / 562	12.25 / 311	30.00 / 762	235 / 106.6	ST091080BR3BA
10 (250mm)	25.12 / 638	13.81 / 351	32.00 / 813	340 / 154.2	ST091100BR3BA
12 (300mm)	29.12 / 740	15.88 / 403	37.00 / 940	505 / 229.1	ST091120BR3BA

REVISIONS				
REV	DESCRIPTION	BY	ECO	DATE
F	UPDATE TITLE BLOCK	FM	0104921	11/24/2014

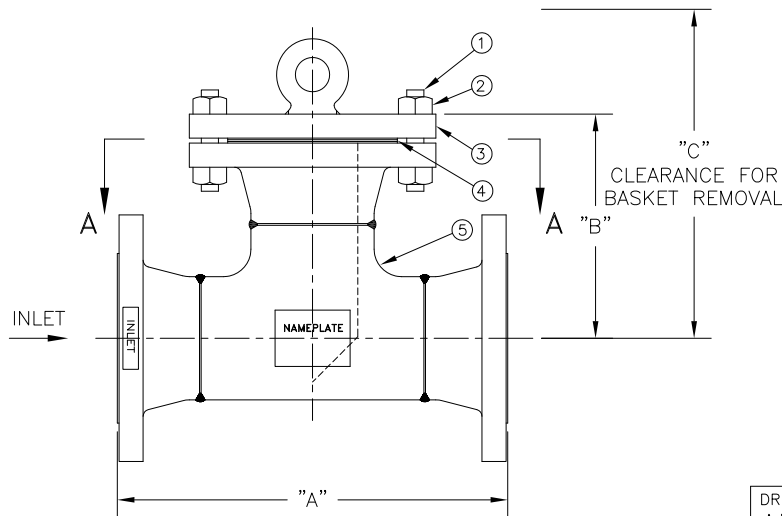
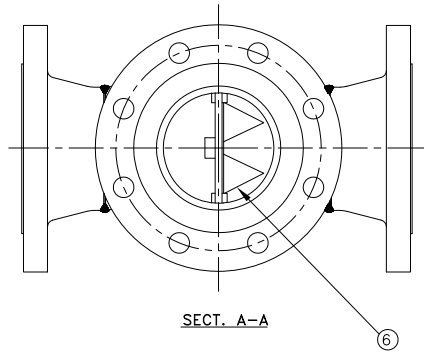

NO.	PART NAME	MATERIAL
1	STUDS	ASTM A193 GR. B7
2	NUTS	ASTM A194 GR. 2H
3	COVER	CARBON STEEL
4	GASKET	NON-ASBESTOS
5	BODY	CARBON STEEL
6	BASKET	316 SSSL
	PERF. / MESH	

NOTES:

1. STRAINER IS DESIGNED AND FABRICATED IN ACCORDANCE WITH ASME B31.1 POWER PIPING CODE.
2. ALL DIMENSIONS ON IN INCHES / MM.
3. ALL FITTINGS CONFORM TO ASME STANDARD.
4. DESIGN PRESSURE: 272 PSIG @ 150°F (18.8 BAR @ 65.6°C)  
200 PSIG @ 400°F (13.8 BAR @ 204.4°C)

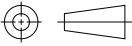
DRAWN BY AB		 HYDRAULICS GROUP FILTRATION DIVISION GALESBURG, MICHIGAN, USA • TINTON FALLS, NEW JERSEY, USA		
SCALE AS DRAWN				
RESTRICTION RESTRICTED		TITLE MODEL 91 TEE STRAINER BOLTED COVER SIZES 2" TO 12" 150#RF FLANGE CARBON STEEL		
SHEET 1 OF 1		DATE 10/6/97	SIZE A	DWG FILENAME SD091BC1
PROJECTION THIRD ANGLE 		REV F		
EATON CORPORATION - CONFIDENTIAL AND PROPRIETARY NOTICE TO PERSONS RECEIVING THIS DRAWING AND/OR TECHNICAL INFORMATION. THIS DOCUMENT, INCLUDING THE DRAWING AND INFORMATION CONTAINED THEREON IS CONFIDENTIAL AND IS THE EXCLUSIVE PROPERTY OF EATON AT ANY TIME. BY TAKING THE POSSESSION OF THIS DOCUMENT THE RECIPIENT ACKNOWLEDGES AND AGREES THAT THIS DOCUMENT CANNOT BE USED IN ANY MANNER ADVERSE TO THE INTEREST OF EATON AND THAT NO PORTION OF THIS DRAWING MAY BE COPIED OR OTHERWISE REPRODUCED WITHOUT THE PRIOR WRITTEN CONSENT OF EATON, IN THE CASE OF CONFLICTING CONTRACTUAL PROVISIONS, THIS NOTICE SHALL GOVERN THE STATUS OF THIS DOCUMENT. 2014 EATON CORPORATION - ALL RIGHTS RESERVED.				

CUSTOMER INFO	
NAME	
P.O. NO.	
TAG NO.	
S.O. NO.	
PART NO.	SEE TABLE