

ITEM NUMBER	VESSEL CODE	BAG SIZE	A IN. / MM	B IN. / MM	C IN. / MM	D IN. / MM	E IN. / MM	F IN. / MM	G IN. / MM	FLOW RATE GPM (MAX)	WEIGHT LBS / KGS
SBL101S62ASSBSP0	FBF2-0101-AB10-020A-L	01	6.84 / 174	18.39 / 467	25.25 / 641	11.92 / 303	34.44 / 875	19.10 / 485	11.5 / 292	90	44 / 20.0
SBL102S62ASSBSP0	FBF2-0102-AB10-020A-L	02	6.84 / 174	33.55 / 852	40.41 / 1026	11.92 / 303	67.52 / 1715	19.10 / 485	28.4 / 721	180	57 / 25.9

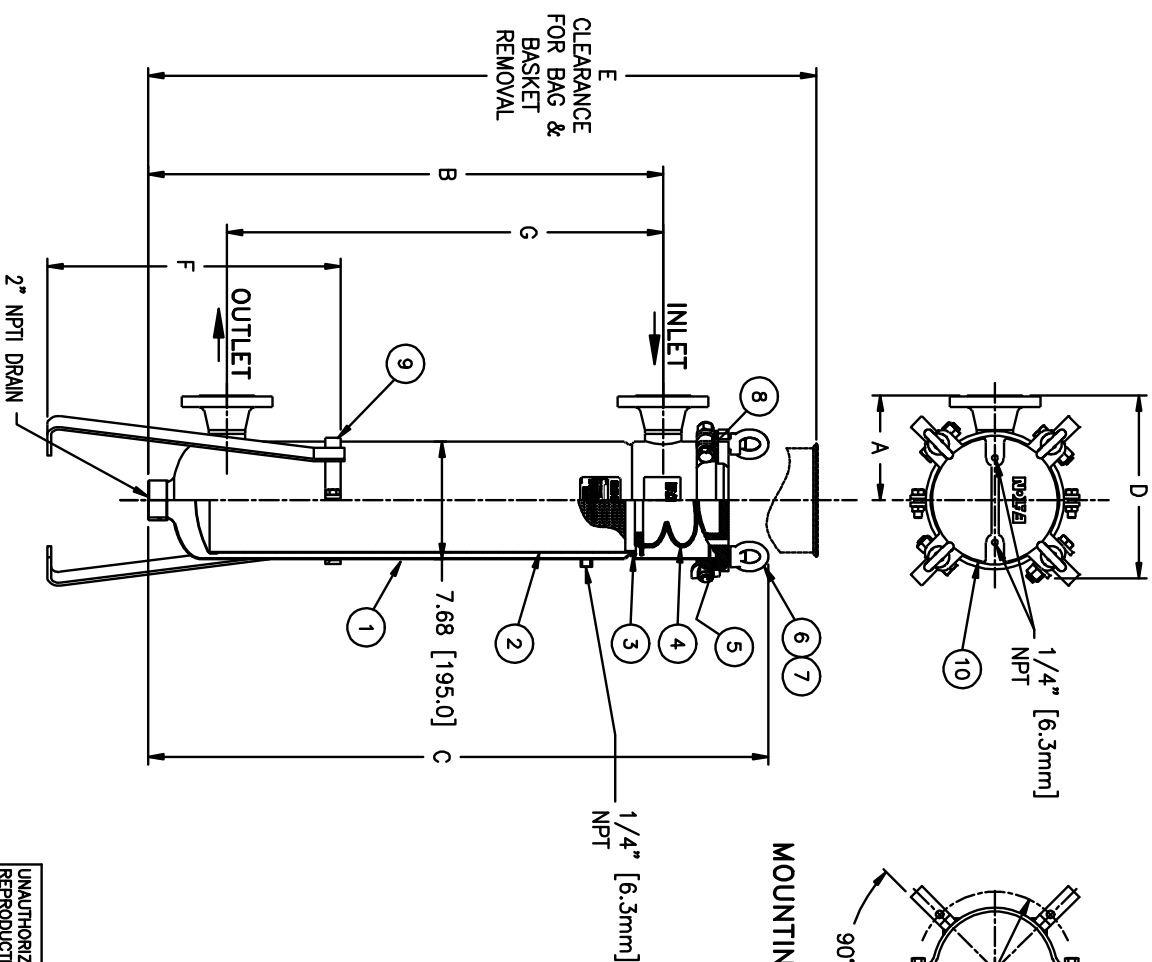

MOUNTING DETAIL

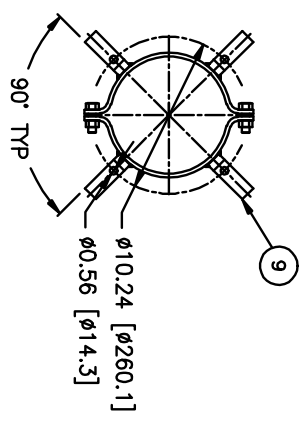

NO.	PART NAME	MATERIAL
1	BODY	316 STAINLESS STEEL
2	RESTRAINER BASKET	316 STAINLESS STEEL
3	BASKET O-RING	BUNA-N
4	BAG HOLD DOWN	KYNAR PUDF
5	O-RING	BUNA-N
6	EYE BOLT	STEEL, ZINC PLATED
7	EYE NUT	STEEL, ZINC PLATED
8	BOLT	STEEL, ZINC PLATED
9	LEGS	CARBON STEEL
10	COVER	316 STAINLESS STEEL

NOTES:

1. INLET/OUTLET FLANGED CONNECTIONS PER ANSI B16.5
2. MAWP: 150 PSI @ 250° F (-20° F @ 150 PSI (10.3 BAR @ 121.1° C) (-28.9° C @ 10.3 BAR) MIDMT: -20° F @ 150 PSI
3. MAXIMUM OPERATING TEMP. 250° F (121.1° C)

CERTIFIED FOR:
P.O. NO.:
SALES ORDER NO.:
QUANTITY:
TAG NO.:
FILTER BAG:

EATON
EATON FILTRATION, LLC
70 WOOD AVENUE SOUTH, ISELIN, NEW JERSEY 08830
NAME: FLOWLINE II FILTER VESSEL
2" 150# FLANGED CONNECTION
STAINLESS STEEL

SIZE	DWG NO	DATE	CERT.	DATE	REV
A		02/09/10			A

ELECTRONIC FILE NAME: FBF211XSF-DPSS0.dwg
REF. EOR DATE 02/09/10
UNAUTHORIZED USE, MANUFACTURE OR REPRODUCTION IN WHOLE OR IN PART IS PROHIBITED. DRAWING, DESIGN AND OTHER DISCLOSURES PROPERTY OF EATON FILTRATION, LLC

DRAWN MAQ DATE 02/09/10 CERT. DATE
FBF211XSF-DPSS0