

A	B	C	D	WG.T	PART NO.
6.88	22.25	---	7.88	45	1TS1000C
				45	1.25TS1000C
7.88	24.25	9.13	9.13	80	1.5TS1000C
				85	2TS1000C

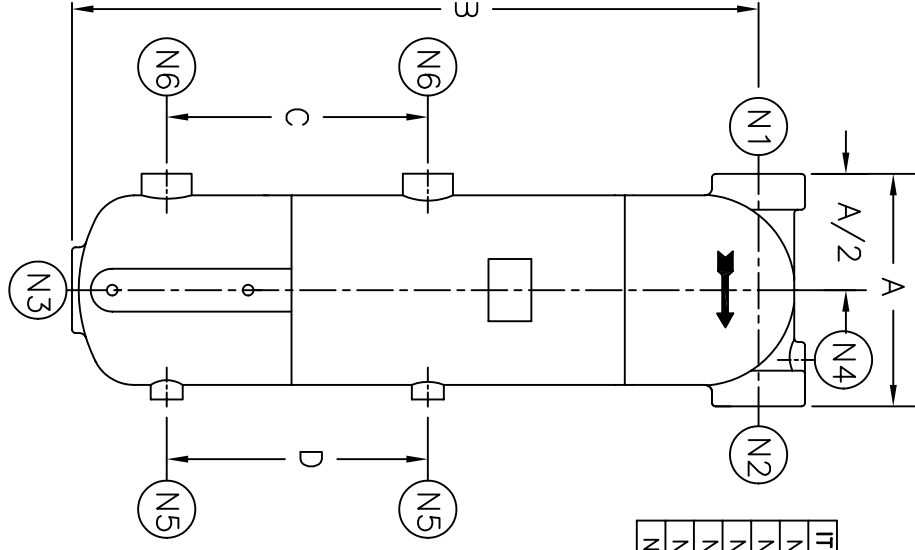

ITEM	DESCRIPTION	NAME	QTY.
N1	NOM. PIPE SIZE	INLET	1
N2	NOM. PIPE SIZE	OUTLET	1
N3	1" NPT	DRAIN	1
N4	1/4" NPT	VENT	1
N5	1/2" NPT 3000# CPLG	WATER GAGE	2
N6	1" NPT 3000# CPLG	LIQUID LEVEL	2

REV	DATE	CHANGE	EGR	BY	APP
A	10/16/98	NEW RELEASE	6812	AB	DP
B	11/1/05	REVISED TITLE BLOCK	D507	FM	LH

NOTES:

- UNITS ARE TO BE DESIGNED, FABRICATED, AND "CODE" STAMPED (IF REQ'D) IN ACCORDANCE WITH ASME B & PV CODE, SECTION VIII, DIVISION 1 IN COMPLIANCE TO CURRENT PUBLISHED ADDENDA.
- ALL DIMENSIONS ARE IN INCHES .
- ALL BOLT HOLES ARE TO STRADDLE NATURAL CENTERLINES.
- SHIPPING WEIGHT: SEE DIMENSION TABLE
- DESIGN DATA:

DESIGN PRESSURE- 1000 PSIG
 DESIGN TEMPERATURE- 650° F
 MIN. DESIGN METAL TEMP.- -20° F @ 1000 PSIG
 HYDROTEST PRESSURE- 1500 PSIG
 CORROSION ALLOWANCE- 0 INCHES
 6. MATERIAL: CARBON STEEL.

CUSTOMER:
 REG. NO.:
 P.O. NO.:
 TAG NO.:

ELECTRONIC FILE NAME:
 SDTS100C.DWG
 TOLERANCES UNLESS OTHERWISE SPECIFIED
 PER ENGINEERING STANDARD ES- ---
 UNAUTHORIZED USE, MANUFACTURE OR
 REPRODUCTION IN WHOLE OR IN PART IS
 PROHIBITED. DRAWING, DESIGN AND
 OTHER DISCLOSURES PROPERTY OF
 EATON FILTRATION, LLC

		EATON FILTRATION, LLC 900 FAIRMOUNT AVENUE, ELIZABETH, NEW JERSEY 07207					
		NAME 1-2" TYPE "TS" GAS/LIQUID SEPARATOR THREADED CONN.					
DRAWN	AB	DATE	10/15/98	CHECKED	DP	DATE	10/15/98
APP	---	DATE	---	SCALE	NTS	EGR	6812
SIZE	DWG	NO	SDTS1000C		REV	B	